



Freedom to play

TP912 Challenger2 Climbing Frame & Accessories

INSTRUCTIONS FOR ASSEMBLY MAINTENANCE AND USE



Important!

These instructions must be followed for safe assembly and use.
Please retain for future reference.

Important!

Vous devez suivre ces instructions pour que le montage
et l'utilisation se fassent en toute sécurité. Veuillez conserver
pour référence ultérieure.

Importante!

Per garantire sicurezza di montaggio ed uso, seguire queste
istruzioni e conservarle per futuro riferimento.

Importante!

Debe seguirse estas instrucciones para un armado y uso seguros.
Sirvase conservarlas para consultarlas en el futuro.

Wichtig!

Diese Anweisung ist für sicheren Aufbau und Gebrauch zu befolgen.
Für künftigen Gebrauch aufbewahren.



Important!

Weight limit: 40kg
Suitable for children
aged: 3 years +

F

INSTRUCTIONS CONCERNANT L'ASSEMBLAGE, L'ENTRETIEN ET L'UTILISATION DE MATÉRIEL *tp*

**Veillez lire attentivement les instructions suivantes et les conserver
à des fins de référence future.**

1. ASSEMBLAGE ET SÉCURITÉ

L'assemblage des équipements/jouets *tp* doit être uniquement effectué par un adulte. Le montage doit être fait en suivant rigoureusement les étapes des instructions fournies. L'aide d'une seconde personne peut grandement faciliter l'assemblage. Cet équipement ne pas à des enfants de moins de 3 ans car il comporte de petits éléments pouvant être avalés ou inhalés. Afin d'éviter les risques de perte de certaines pièces de taille réduite, il est conseillé de les disposer sur un plateau ou sur un support du même genre. Lors de l'assemblage, il est recommandé de manipuler les pièces avec précaution car celles-ci peuvent présenter des aspérités résultant du procédé de fabrication. S'il manque des pièces, ne pas utiliser le matériel tant que la ou les pièces en question n'ont pas été montées. Service Clients *tp*: tel +44 (0)1 299 872804 (service téléphonique en langue anglaise uniquement).

2. INSTALLATION

Notre matériel ne doit en aucun cas être installé sur des surfaces en dur (béton, asphalte, etc.) à moins que la surface du sol sous le matériel (plus la marge de sécurité recommandée à l'extérieur du périmètre total du matériel) ne soit recouverte d'un revêtement de sécurité (cf. schéma page 14). Il est recommandé d'installer le matériel sur de l'herbe ou du sable ou une aire recouverte d'un revêtement de sécurité approprié. Les équipements *tp* doivent être installés sur une surface plane.

3. UTILISATION

Nos équipements/jouets sont destinés à l'usage extérieur familial et ont été conçus, sauf mention spéciale, à l'intention des enfants entre 3 et 12 ans; ils ne doivent EN AUCUN CAS être utilisés par d'autres personnes. Nos équipements/jouets sont entièrement sûrs s'ils sont utilisés conformément aux présentes instructions.

4. SUPERVISION

La supervision permanente d'un adulte est nécessaire lors de l'utilisation des équipements/jouets *tp* par des enfants. Pour des raisons de sécurité, il est conseillé de s'assurer que les enfants utilisent les équipements/jouets correctement et ne portent pas de casque pour vélo, ni de vêtements lâches ou de bijoux, qui pourraient être retenus ou s'accrocher.

5. UTILISATION ET CONDITIONS MÉTÉOROLOGIQUES

Une prudence accrue est recommandée lors de certaines conditions météorologiques. Les équipements/jouets de plein air deviennent glissants avec la pluie. Lorsqu'il gèle, il est recommandé de faire attention car les lèvres et la langue peuvent "coller" au métal. Par temps chaud et en cas d'exposition au soleil, il convient de vérifier régulièrement si la température de l'équipement/jouet n'est pas trop élevée, spécialement au niveau des éléments métalliques et des toboggans. En cas de doute, il est conseillé d'interdire l'usage du matériel.

6. JEUX AQUATIQUES

Les équipements/jouets aquatiques peuvent devenir extrêmement glissants, aussi une supervision attentive et une prudence accrue sont recommandées lors d'usage d'équipements de plein air utilisant de l'eau tels que des piscines gonflables, des toboggans aquatiques, etc.

7. ENTRETIEN

Il est essentiel qu'un adulte se charge de contrôler chaque équipement/jouet à intervalles réguliers. L'ensemble de l'équipement/jouet, et en particulier toutes les pièces d'assemblage et les systèmes d'attache, doit être vérifié au moins une fois par mois. Si des pièces présentent des signes d'usure, il convient de remplacer la ou les pièces en question. Dans ce cas, l'équipement/jouet ne devra pas être utilisé tant que la ou les pièces de rechange n'auront pas été montées. Les Produits tubulaires galvanisés nécessiteront éventuellement un entretien occasionnel. Si de la rouille apparaît sur la structure, il convient de l'enlever avec une brosse métallique ou du papier de verre à gros grains, pour ensuite appliquer sur la surface à traiter une peinture non toxique.

8. CADRES DE BALANÇOIRE

Toujours utiliser les piquets fournis à cet effet. En cas de doute concernant leur efficacité, il est alors conseillé de bétonner fermement ces piquets. Ne jamais bétonner les tubes du cadre.

9. BALANÇOIRES, BARRES DE TRAPÈZE, ANNEAUX, etc.

Lors de l'assemblage, il est essentiel de s'assurer qu'il n'existe aucun contact métal/métal sur les pièces mobiles. Pour des raisons de sécurité, il est important d'apprendre aux enfants de ne pas passer devant ou derrière des balançoires en mouvement, de ne pas sauter d'une balançoire en mouvement et de ne pas faire aller une balançoire à vide ou l'utiliser comme une "vrille".

10. CORDAGES

Avec le temps, les cordages auront tendance à se dégrader. En cas de signes d'usure des cordages, il convient de remplacer le jouet ou l'équipement en question.

11. TRAMPOLINES

Nous vous conseillons d'équiper tout trampoline de patins de sécurité. Nos trampolines ont été conçus en tant que jouets et, sauf mention contraire, ne doivent pas être utilisés comme équipement de gymnastique.

12. RISQUES D'INCENDIE ET NON-USAGE

Ne jamais placer ou utiliser les équipements/jouets *tp* à proximité de flammes nues. Si vous devez vous débarrasser d'un équipement/jouet, démontez-le en veillant à enlever toutes les vis. Si ce matériel doit être momentanément entreposé, assurez-vous de le maintenir hors de portée des enfants.

Les présentes instructions ont été rédigées pour la sécurité de votre enfant et nous vous demandons de bien vouloir suivre nos conseils.

Fabriqué en Angleterre par: **tp Activity Toys**.

ISTRUZIONI DI MONTAGGIO, MANUTENZIONE E UTILIZZO DEI GIOCHI *fp*

Leggere attentamente tutte le seguenti informazioni e conservarle per riferimento futuro.

1. INFORMAZIONI DI MONTAGGIO E SICUREZZA

I giochi *fp* devono essere montati da un adulto. Devono essere eretti seguendo esattamente le istruzioni di montaggio fornite. La procedura di montaggio viene facilitata se si fa ricorso all'assistenza di un'altra persona. Questa confezione può contenere pezzi piccoli e il suo contenuto, non è adatto per i bambini al di sotto di 3 anni di età. Si raccomanda di mettere i pezzi più piccoli in un vassoio o in un recipiente simile per evitare frustrazione e disappunto, o di perderli. Prestare particolare attenzione durante il montaggio del gioco, dato che il processo di fabbricazione può lasciare talvolta spigoli taglienti e pezzetti di metallo sciolti di scarto. Se dovessero per caso mancare dei pezzi, non usare il gioco prima di avere montato i pezzi mancanti di ricambio.

Per la linea del Servizio Clienti *fp*, chiamare il numero +44 (0)1299 872804 (in inglese).

2. POSIZIONAMENTO DEI GIOCHI

Non posizionare in alcun caso i giochi su superfici dure come quelle di calcestruzzo o di asfalto, a meno che il terreno sotto il gioco e lo spazio libero circostante raccomandato siano coperti con una superficie di sicurezza (vedere il disegno a pagina 14). Superfici di tipo adatto sono quelle erbose, sabbiose o per giochi intese per tale uso. I giochi *fp* devono essere posizionati su terreno in pari.

3. UTILIZZO

A meno che sia indicato altrimenti, i giochi *fp* sono progettati e costruiti per essere usati per la famiglia all'aperto domestico dai bambini di età fra 3 e 12 anni, e non devono essere usati da altre persone. Un cattivo uso può provocare lesioni personali.

4. SORVEGLIANZA

I bambini devono essere sempre sorvegliati quando si divertono con i giochi *fp*, ed è necessario insegnare loro a non usare i giochi in maniera incorretta o pericolosa. Si raccomanda che i bambini non indossino indumenti sciolti o articoli di gioielleria che durante il gioco possono restare impigliati o agganciati. I bambini non devono indossare caschi per bicicletta quando si divertono con i giochi *fp*.

5. CONDIZIONI ATMOSFERICHE

Prestare particolare attenzione al cambiare delle condizioni atmosferiche, dato che con la stagione bagnata le superfici possono diventare scivolose. Quando la temperatura è sotto zero le labbra e la lingua possono aderire alle parti di metallo, mentre nella stagione calda e soleggiata i vari elementi dei giochi possono diventare molto caldi; bisogna controllarne perciò con regolarità la temperatura, specialmente quella dei componenti metallici e degli scivoli. Non usare i giochi se sussiste alcun dubbio sulla loro sicurezza.

6. GIOCHI CON L'ACQUA

Nei giochi con l'acqua, molte superfici possono diventare scivolose. Quando ad altre forme di giochi all'aperto si abbina l'acqua (come ad esempio nelle piscine basse per bambini piccoli, negli scivoli ad acqua, ecc.) bisogna essere particolarmente attenti ed esercitare stretta sorveglianza.

7. MANUTENZIONE

Come per tutti i giochi, è d'importanza vitale che le attrezzature siano controllate regolarmente e spesso da un adulto. Controllare tutto il gioco almeno una volta al mese, prestando particolare attenzione alle connessioni e ai dispositivi di fissaggio. Se qualsiasi parte presenta segni di deterioramento o di usura, può essere necessario cambiarla. Mancando di farlo si può provocare il cattivo funzionamento del prodotto e produrre lesioni personali. Non lasciare che i bambini usino questo gioco prima che sia stato installato nel modo dovuto e controllato attentamente. I prodotti tubolari in acciaio zincato possono richiedere manutenzione occasionale. Se appare ruggine sulla loro superficie, rimuoverla usando una spazzola metallica o tela smeriglio grossa, e trattare poi l'area interessata con una vernice non tossica.

8. TELAI LATERALI

Questi devono essere sempre usati insieme ai picchetti forniti. Se i picchetti non offrono supporto sufficiente, si raccomanda di fissarli in posizione con una gettata di calcestruzzo. Non fissare mai nel calcestruzzo le gambe delle intelaiature per altalene.

9. GIOCHI AD OSCILLAZIONE

Nel montare i giochi ad oscillazione, è d'importanza vitale che le parti in movimento non abbiano elementi di metallo in contatto con altre parti metalliche. Insegnare ai bambini a non passare davanti o dietro gli oggetti in movimento, a non fare ruotare od oscillare i sedili delle altalene vuoti, e a non scendere dai giochi ad oscillazione prima che si siano fermati.

10. FUNI

Con l'andare del tempo queste funi si deteriorano. Cambiare il gioco non appena appaiono segni di deterioramento.

11. TRAMPOLINI

Si raccomanda di montare cuscini di sicurezza su tutti i trampolini. I trampolini *fp* sono progettati come giochi e, a meno che sia indicato altrimenti, non devono essere usati come attrezzature ginniche.

12. RISCHI E PROCEDURE PER L'ELIMINAZIONE

Non permettere mai che i giochi *fp* siano posizionati od usati vicini al fuoco. Quando diventa necessario disfarsi dei giochi, rimuovere tutti i bulloni e smontarli, tenendoli fuori della portata dei bambini fino a quando possono essere eliminati nel modo dovuto.

Queste istruzioni sono preparate nell'interesse della sicurezza dei bambini e si raccomanda di seguire tutti i consigli ivi contenuti.

Made in England: *fp* Activity Toys.

E

INSTRUCCIONES DE MONTAJE, MANTENIMIENTO Y USO DE LOS JUGUETES *tp* **Lea detenidamente toda la información adjunta y consévela para futuras consultas.**

1. INFORMACIÓN SOBRE MONTAJE Y SEGURIDAD

Los juguetes *tp* deben ser montados por un adulto. Deben armarse siguiendo fielmente las instrucciones de montaje, y será más fácil hacerlo con la ayuda de otro adulto. Este paquete puede incluir piezas pequeñas, por lo que no es apropiado para niños menores de 3 años. Recomendamos que coloque las piezas pequeñas en una bandeja o recipiente similar, para evitar la frustración de no saber dónde las ha puesto. Tenga cuidado durante el montaje, ya que tras el proceso de fabricación pueden aparecer a veces bordes afilados y pequeños restos metálicos. Si falta alguna pieza, el juguete no debe usarse hasta que se hayan procurado las piezas de repuesto. El teléfono de atención al cliente de *tp* es: +44 (0)1299 872804 (en inglés).

2. EMPLAZAMIENTO

Nuestros juguetes no deben, en ningún caso, colocarse sobre una superficie dura, por ejemplo de cemento o asfalto, a menos que el suelo bajo el juguete y la zona libre recomendada estén cubiertos con una superficie segura (consulte el gráfico de la página 14). Algunos ejemplos de superficies aptas serían de hierba, arena o superficies de juego preparadas para este propósito. Los juguetes *tp* deben emplazarse en suelo llano.

3. USO

Los juguetes *tp* están diseñados y fabricados para el uso doméstico al aire libre para sólo por niños de entre 3 y 12 años, a menos que aparezca otra indicación, y no deben ser usados por personas de otras edades. El uso inapropiado de estos productos puede causar daños personales.

4. SUPERVISIÓN

Mientras jueguen con los juguetes *tp*, los niños deben ser supervisados, y se les debe advertir que no deben usarlos de un modo inadecuado o peligroso. Recomendamos que no lleven prendas muy amplias o adornos que se puedan enganchar mientras juegan. No deben llevar cascos de ciclista cuando juegan con juguetes *tp*.

5. CONDICIONES METEOROLÓGICAS

Durante los cambios meteorológicos se deben tomar mayores precauciones. En concreto, los juguetes para exteriores pueden resultar resbalosos en la lluvia, y los labios y la lengua pueden pegarse al metal a temperaturas inferiores a los 0°C. En días calurosos y soleados, puede que algunas piezas se recalienten, por lo que la temperatura del juguete debe comprobarse con frecuencia mientras se usa, especialmente las piezas metálicas y los toboganes. En caso de albergar alguna duda sobre la seguridad del uso del juguete, deben abstenerse de usarlo.

6. JUEGOS DE AGUA

Muchas superficies pueden volverse resbalosas cuando se juega en el agua. Se debe prestar un mayor cuidado y una supervisión más estricta cuando se combina el agua (por ejemplo, una piscina inflable, toboganes acuáticos, etc.) con otras formas de jugar al aire libre.

7. MANTENIMIENTO

En el caso de todos los juguetes, es de suma importancia que el equipo sea revisado con bastante regularidad por un adulto. El juguete completo debería ser revisado al menos una vez al mes, prestando especial atención a las conexiones y las sujeciones. Si alguna pieza presenta señales de desgaste o rotura, puede que necesite ser reemplazada. De no hacerlo, puede que el producto deje de funcionar correctamente y que cause un daño. No se debe permitir que los niños usen el juguete hasta que esté instalado y haya sido revisado. Los productos tubulares galvanizados pueden necesitar trabajos de mantenimiento ocasionales. Si aparece óxido en la superficie, debe quitarse con un cepillo de alambre o con papel de lija grueso, y se debe tratar la zona con una pintura no tóxica.

8. ESTRUCTURAS DE LOS COLUMPIOS

En estas estructuras, siempre deben utilizarse las estacas que se facilitan. Si no proporcionan una sujeción suficiente, recomendamos que las fije con hormigón. Nunca fije las patas de un columpio con cemento.

9. JUGUETES DE COLUMPIAR

Cuando se instalan los juguetes de columpiar, es de suma importancia que las piezas móviles metálicas no tengan contacto entre sí. Se debe advertir a los niños que no deben pasar por delante o por detrás de los columpios, ni retorcer o balancear los asientos vacíos, ni bajarse de ellos cuando están en movimiento.

10. CUERDAS

Estas cuerdas se desgastarán con el tiempo. Cuando aparezcan síntomas de desgaste, se deberá reemplazar el juguete.

11. TRAMPOLINES

Recomendamos que se instalen plataformas de seguridad para todos los trampolines. Los trampolines *tp* han sido diseñados como juguetes y no se deben usar como equipo gimnástico, a menos que se especifique lo contrario.

12. PELIGRO DE INCENDIO Y CÓMO TIRAR EL JUGUETE

Nunca permita colocar o usar un juguete *tp* cerca del fuego. Llegado el momento de tirar el equipo, retire todos los tornillos y desmóntelo. Guárdelo fuera del alcance de los niños hasta el momento de deshacerse del mismo.

Estas instrucciones se facilitan para la seguridad del niño. Le rogamos que siga nuestros consejos.

Fabricado en Inglaterra por: ***tp* Activity Toys**.

ANLEITUNG ZUR MONTAGE, WARTUNG UND GEBRAUCH VON **tp** SPIELGERÄT

Bitte lesen Sie diese Anleitung vor der Montage und der ersten Benutzung sorgfältig durch. Bitte bewahren Sie diese Anleitung zur Information, bzw. für Wartungsarbeiten und Ersatzteilbeschaffung auf.



1. MONTAGE

Dieses Spielgerät muß von einem Erwachsenen aufgebaut werden. Befolgen Sie dabei genau die Bauanleitung. Dieser Artikel enthält Kleinteile und ist daher nicht für Kinder unter 36 Monaten geeignet. Bitte achten Sie auf scharfkantige Bohrungen und Späne, die unter Umständen in der Herstellung dieses Spielgerätes anfallen können. Sollten Einzelteile fehlen, so darf das Spielgerät nicht benutzt werden. Bitte sorgen Sie dafür, daß die notwendigen Ersatzteile montiert werden. Sie können Einzelteile beim tp Kundenservice unter +44 (0)1299 872 804 bestellen.

2. STANDORT

Unsere Spielgeräte dürfen unter keinen Umständen auf hartem Untergrund (Asphalt oder Beton) aufgestellt werden und sollte ebenerdig sein. Der Standort muß so gewählt werden, daß ausreichende Sicherheitsabstände gewährleistet sind (siehe Zeichnung auf Seite 14).

3. VERWENDUNGSBEREICH

tp Spielgeräte dürfen nur bestimmungsgemäß verwendet werden, d.h. als Kinderspielgerät im ausschließlich privaten Garten für eine dem Gerät angemessene Anzahl von Kindern von 3 bis 12 Jahre alt. Jegliche andere Verwendung ist unzulässig und möglicherweise gefährlich. **tp Activity Toys** übernimmt keine Haftung für Schäden, die aus nicht zweckgemäßen Gebrauch entstehen.

4. BEAUFSICHTIGUNG

Kinder sollten nur unter Beaufsichtigung von Erwachsenen mit **tp** Spielgeräten spielen und sollten über den zweckmäßigen Gebrauch unterrichtet werden. Wir empfehlen, daß Kinder keine lose Kleidung oder Schmuck beim Spielen tragen, außerdem dürfen keine Fahrradhelme getragen werden.

5. WETTEREINFLÜSSE

Achten Sie darauf, daß unser Spielzeug, vor allem die Plastik- und Metallteile, ganzjährig allen Wetterbedingungen ausgesetzt ist. Stellen Sie sicher, daß unter widrigen Bedingungen nicht mit dem Spielgerät gespielt wird.

6. SPIELEN MIT WASSER

Beim Spielen in Verbindung mit Wasser (Planschbecken, Wasserrutsche, usw.) sollte besondere Vorsicht geboten sein, da das Spielgerät sehr rutschig werden kann.

7. WARTUNG

Es ist für Spielzeug im allgemeinen notwendig, daß Kleinteile und Verbindungen von einem Erwachsenen in regelmäßigen Abständen auf ihre Funktionstüchtigkeit überprüft werden. Führen Sie in monatlichen Abständen, dem Spielbetrieb angemessen, regelmäßige Kontrollen aller Schraub- und anderen Verbindungen durch. Ein nicht angemessenes Überprüfen des Zustandes, kann die Lebensdauer des Spielgerätes verringern und die Sicherheit Ihrer Kinder gefährden. Verschlossene Teile sollten frühzeitig ersetzt werden. Zink galvanisierte Teile können unter Umständen Roststellen aufweisen. Sie sollten diese mit einer Drahtbürste behandeln und mit ungiftiger Schutzfarbe überstreichen.

8. SCHAUKELGESTELLE

Bitte sorgen Sie dafür, daß unsere Schaukelgestelle immer in Verbindung mit den entsprechenden Bodenankern verwendet werden. Sollten die Bodenanker nicht ausreichenden Halt gewähren, müssen Sie die Anker einbetonieren. Bitte wenden Sie sich mit weiteren Fragen an den **tp** Kundenservice unter +44 (0)1299 872804.

9. SCHAUKELSTITZE

Bei der Montage von Schaukelsitzen muß darauf geachtet werden, daß unter keinen Umständen Metallteile aufeinander reiben. Kinder müssen unterwiesen werden, nicht hinter oder vor bewegenden Schaukeln zu spielen.

10. SEILE

Seile werden sich durch Gebrauch abnutzen. Es ist daher notwendig, alle Seile in angemessenen Abständen nach Funktion und Verschleiß hin zu überprüfen und gegebenenfalls zu ersetzen.

11. TRAMPOLINE

Wir empfehlen, daß unsere Trampoline mit den jeweiligen Sicherheitsmatten benutzt werden. **tp** Trampoline sind ausschließlich als Kinderspielzeug und nicht als Sportgerät zu gebrauchen.

12. ENTSORGUNG

Bevor Sie Ihr Gerät entsorgen, entfernen Sie alle Schraubverbindungen und lagern es so, daß Kinder keinen Zugriff auf einzelne Teile haben.

Es ist ratsam, die Kleinteile während der Montage an einem sicheren Platz aufzubewahren, damit Sie keine Schrauben oder Muttern verlieren. Dieses Spielgerät muß von einem Erwachsenen aufgebaut werden.

Hergestellt in England von: **tp Activity Toys**.



1

INSTRUCTIONS FOR ASSEMBLY, MAINTENANCE AND USE OF *tp* TOYS

**Please read carefully and keep all enclosed information
or future reference.**

1. ASSEMBLY AND SAFETY INFORMATION

tp toys must be assembled by an adult. They must be erected exactly in accordance with the assembly instructions. Enlisting the aid of a helper will make assembly easier. This pack may contain small parts and is not suitable for children under 36 months. We recommend that you place small parts on a tray, or something similar, to prevent the frustration and disappointment of mislaying them. Please take care during assembly as the manufacturing process can sometimes result in the occasional sharp edge and small pieces of waste metalwork. Should there be any missing parts, the toy must not be used until replacement parts have been fitted - the *tp* Customer Services line is +44 (0)1299 872804 (English Speaking).

2. SITING

Under no circumstances should any of our toys be positioned on hard surface such as concrete or asphalt, unless the ground under the toy plus the recommended freespace area is covered with a safety surface (please refer to diagram on page 14). Examples of suitable surfaces are grass, sand or a play surface intended for this use. *tp* toys should be sited on level ground.

3. USAGE

tp toys are designed and made for family outdoor domestic use only by children aged between 3 and 12 years, unless otherwise stated, and must not be used by anybody else. Misuse can result in injury.

4. SUPERVISION

Children should always be supervised while they are playing on *tp* toys and should be instructed not to use the toy in an inappropriate or hazardous manner. We recommend that they do not wear loose-fitting clothing or jewellery that may catch or snag during play. Children should not wear cycle helmets while playing on *tp* toys.

5. WEATHER CONDITIONS

Special care should be taken as weather conditions change. In particular, outdoor toys can become slippery in wet weather and tongues and lips can stick to metalwork at subzero temperatures. In warmer and sunnier weather, parts can become hot, and the temperature should be regularly checked during play, especially metal parts and slides. If there is any doubt over safety then the toys should not be used.

6. WATER PLAY

Many surfaces can become slippery during water play. Extra caution and supervision is required when combining water (e.g. paddling pools, aqua slides etc.) with other forms of outdoor play.

7. MAINTENANCE.

With all toys it is vital that the equipment is checked regularly and often by an adult. The complete toy should be checked at least once a month, and particular attention should be paid to connections and fastenings. If any parts exhibit signs of wear and tear, they may need to be replaced. Checks must be carried out at the beginning of the usage season as well as at regular intervals throughout the usage season. Check all nuts and bolts for tightness and tighten when required. Failure to do this may result in the product malfunctioning and causing injury. Children must not be allowed to use the toy until properly installed and checked. Galvanised tubular products may require occasional maintenance. If surface rust appears it should be removed with either a wire brush or coarse sandpaper, and the area treated with a non-toxic paint.

8. SWING FRAMES

These must always be used with the stakes provided. If the stakes do not give enough hold, we recommend that you concrete them in place. Never set the legs of a swing frame in concrete.

9. SWINGING TOYS

When fitting swinging toys it is vital that moving parts have no metal to metal contact. Children should be instructed not to pass in front of or behind moving items, not to twist or swing an empty swing seat, and not to get off a swinging toy when it is in motion.

10. ROPES

These ropes will degrade over time. When signs of degradation appear, the toy should be replaced.

11. TRAMPOLINES

We recommend the fitting of safety pads for all trampolines. *tp* trampolines are designed as toys and should not be used as gymnastic equipment, unless otherwise stated.

12. FIRE RISKS AND DISPOSAL

Never allow *tp* toys to be placed or used near a fire. When it becomes necessary to dispose of your equipment, remove all bolts and disassemble. Store out of the reach of children until it can be properly disposed of.

These instructions are issued in the interest of child safety, and we do ask you to follow our advice.

Made in England by: *tp* Activity Toys.

tp 912 Challenger2 Climbing Frame

2

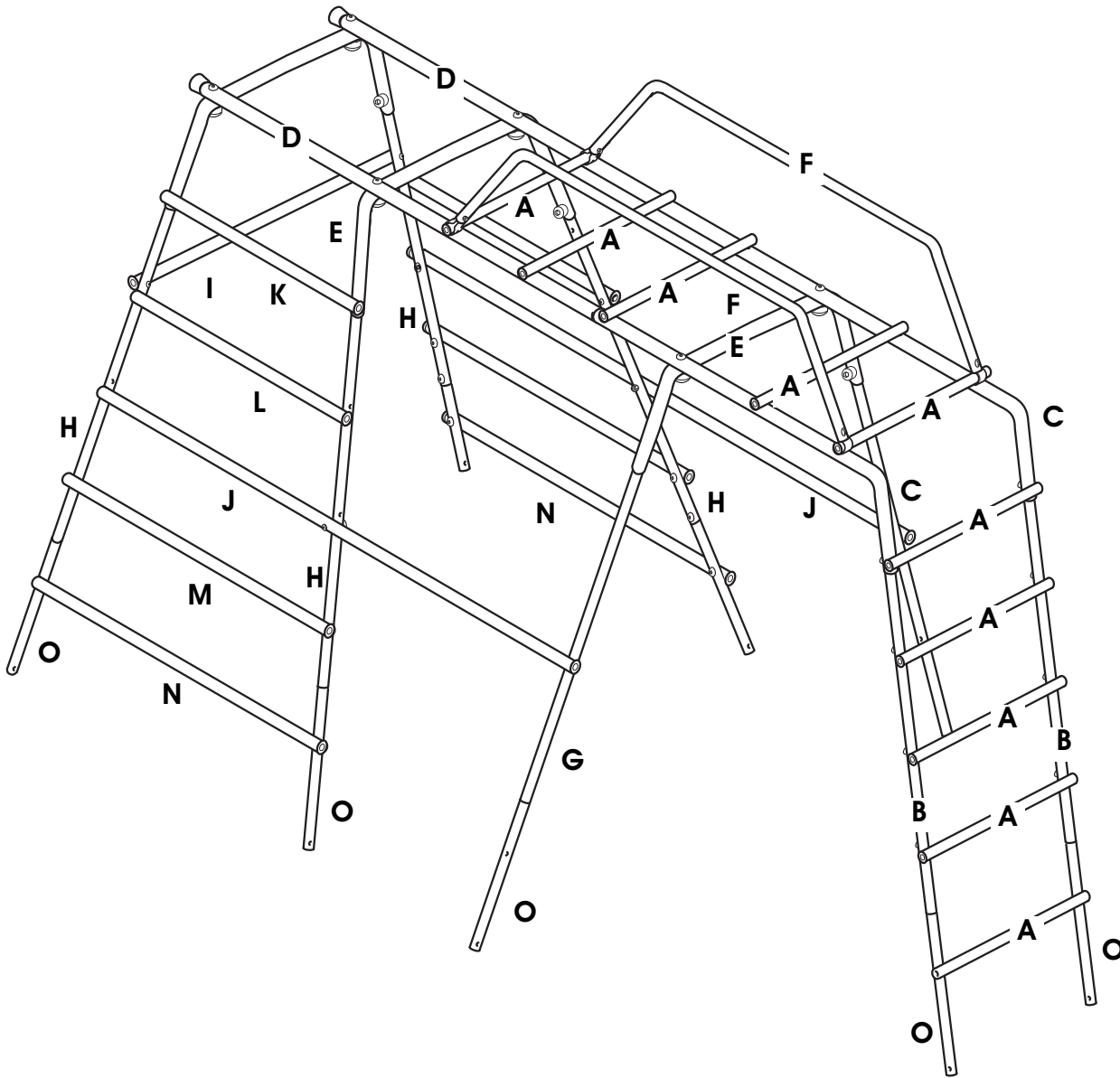

7

Main Box

Contents - Please check

Contenu - Veuillez vérifier

Siete pregati di controllare il contenuto

Verifique el contenido

Inhalt - Bitte Überprüfen

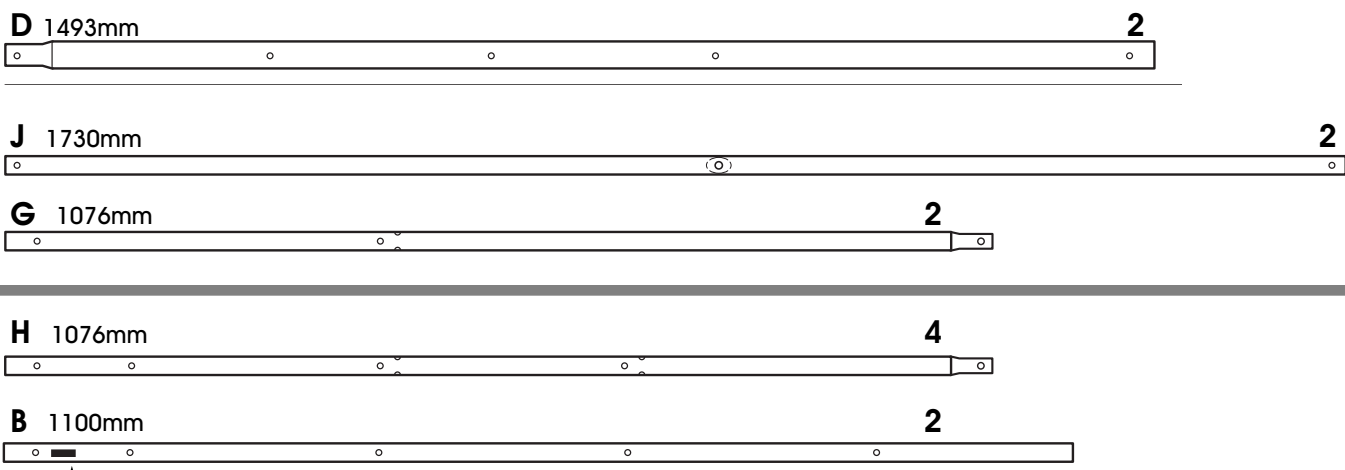
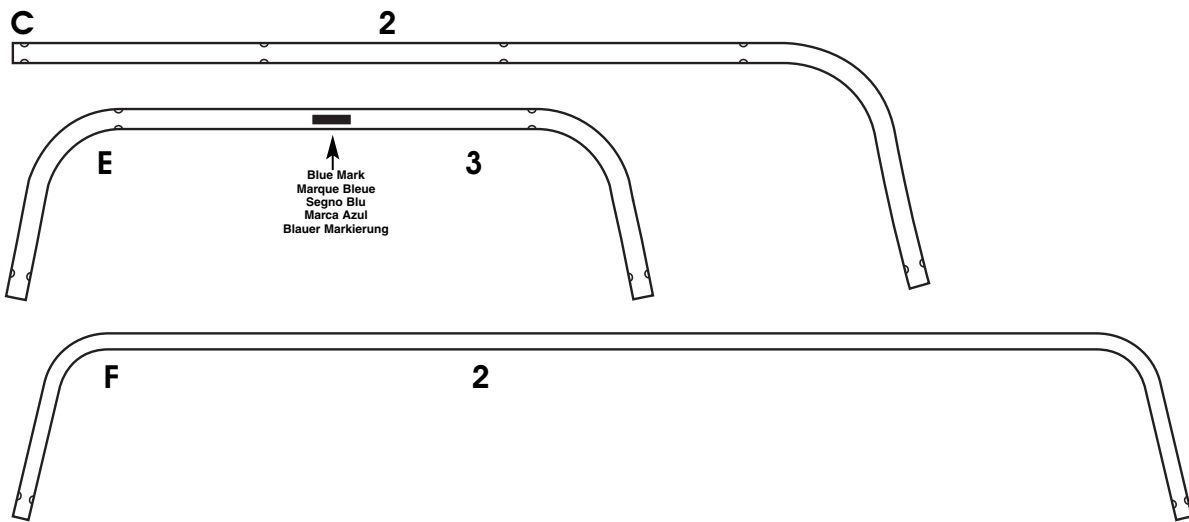
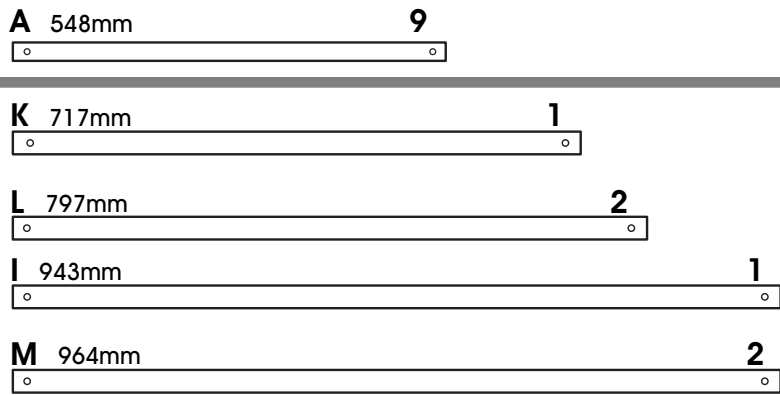





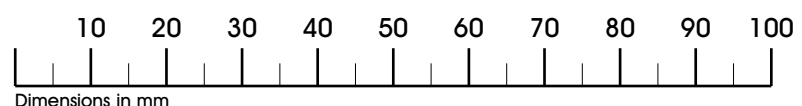
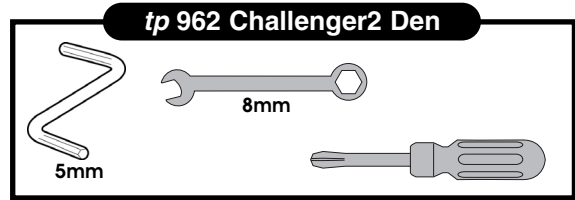



Tools







You will need:
Vous aurez besoin de:
Sie benötigen:
Avrete bisogno:
Precisarà:

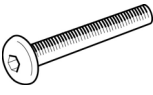
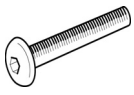

Small Parts Bag 1

FA 7111 	FA 5175 M6 	FA 5174 M8 	PM 7559 22mm 	PM 7246 	PM 7593 	PM 7074 25mm 	Pm 7075 29mm 
36	10	6	18	6	4	8	2

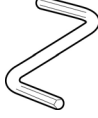
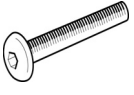



Small Parts Bag 2

FA 7244 40mm 	FA 7243 30mm 	FA 7245 55mm 	FA 7591 65mm 	FA 7560 	FA 7241 	FA 7253 35mm 	PM 7592 25mm 
36	4	2	6	4	1	4	18



Full Height Extension Kit Bag

A 548mm 	1	O 510mm 	8	FA 5290 	6
N 1048mm 	2				

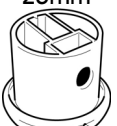
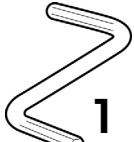
Extension Kit Small Parts Bag

Bag 3			Bag 4			
FA 7111 	PM 7559 22mm 	PM 7038 22mm 	FA 7244 40mm 	FA 7242 16mm 	PM 7592 25mm 	Pm 7241 
14	2	8	6	8	4	1

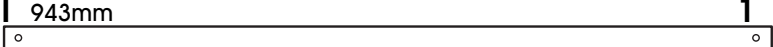
OPTIONAL tp 860 Challenger2 Platform set - Box

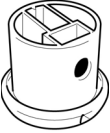
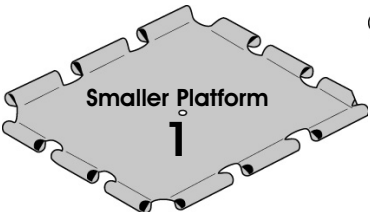
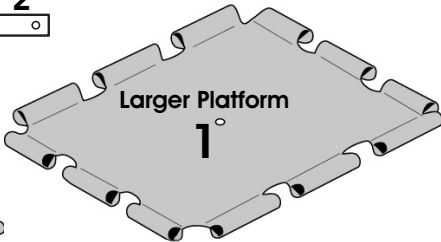
N 1048mm 	2				
I 943mm 	1				
FA 7111 	FA 7244 40mm 	PM 7592 25mm 	Smaller Platform 	Larger Platform 	
6	6	6	1	1	

Bolt Tightening Guide



OPTIONAL tp 850 Challenger2 Toddler Kit - Bag

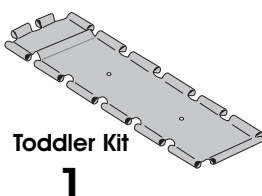

OPTIONAL tp 962 Challenger2 Den - Box

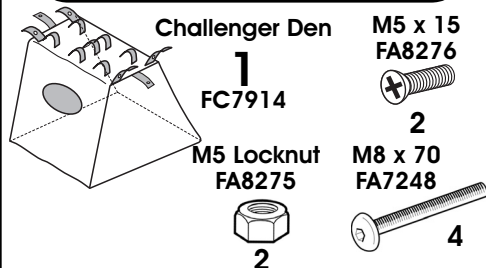

DO STAGE 3 & 4 BEFORE YOU START THE ASSEMBLY OF THE FRAME.

Terminez les étapes 3 et 4 avant de commencer à monter le cadre.

Prima di cominciare ad assemblare l'intelaiatura, completare la fase 3 e 4.

Complete los pasos 3 y 4 antes de comenzar a armar el armazón.

Schritte 3 und 4 fertigstellen, bevor Sie den Rahmen zusammenbauen.

3

Bag 1

PM 7559



18

FA 7111



34

Bag 2

PM 7592



16

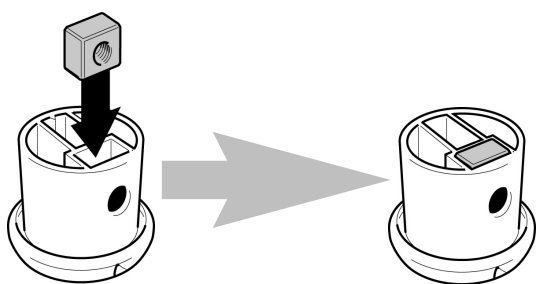

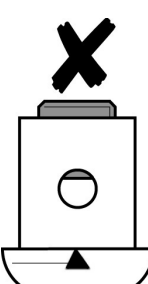

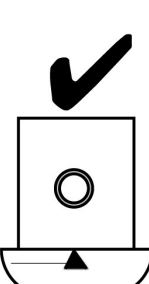

x34

Preparation

Préparation

Preparazione

Preparación

Vorbereitung

Main Box

4

A 548mm **9**



K 717mm **1**



L 797mm **2**



I 943mm **1**



M 964mm **2**



J 1730mm **2**



x34

PM 7559



18

PM 7592

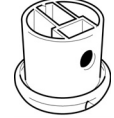

16

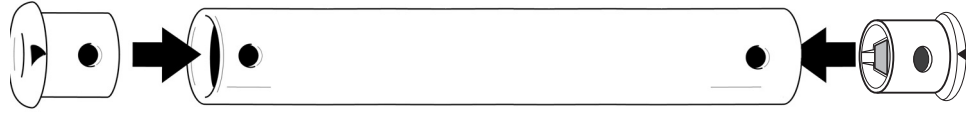

x17

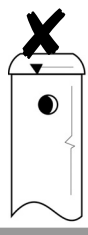

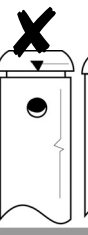

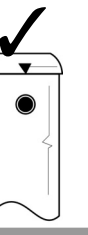

5

Bag 2
FA 7244
40mm



6

A 548mm **3**

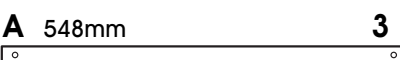

B 1100mm **2**

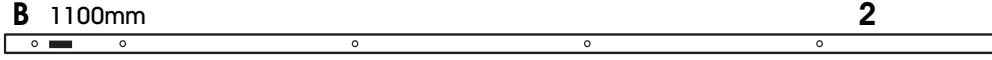

We recommend that all fastenings are tightened only fingertight until the product is completely assembled.

Tant que le montage n'est pas entièrement terminé, nous recommandons de serrer les fixations à la main seulement.

Si raccomanda di serrare solo con le dita i dispositivi di fissaggio prima del montaggio completo.

Recomendamos que los fijadores sólo estén ajustados a mano hasta que se haya armado totalmente.

Wir empfehlen, alle Befestigungen zuerst nur fingerfest anzuziehen, bevor das Erzeugnis voll zusammengebaut ist.

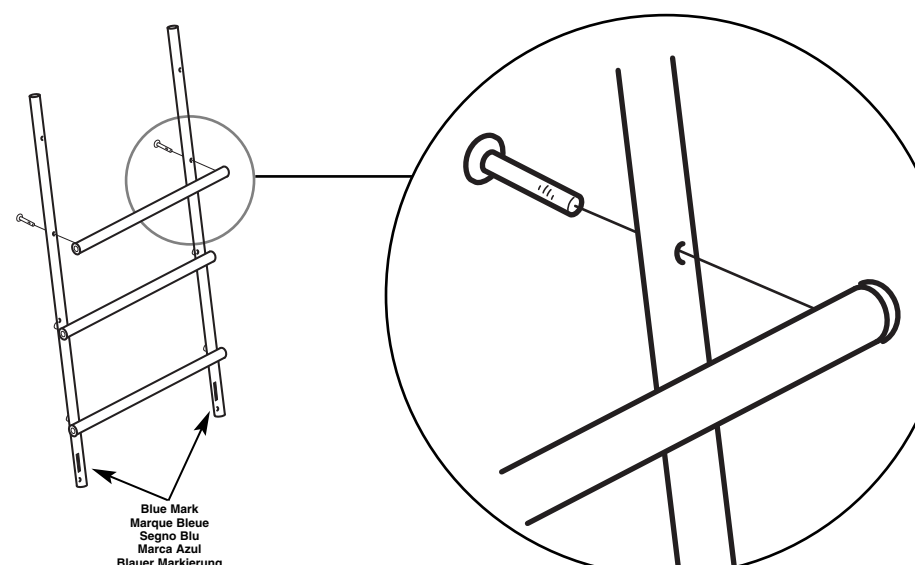

Blue Mark
Marque Bleue
Segno Blu
Marca Azul
Blauer Markierung

6

Bag 2
FA 7244
40mm

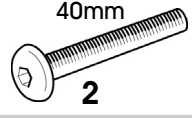

2

C 1350mm **2**

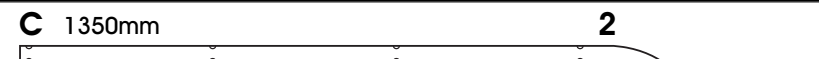

A 548mm **1**



D 1493mm **2**

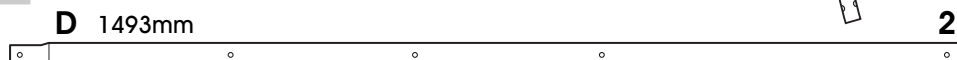

IMPORTANT PLEASE READ

 **15**

Optional tp 850 FIT TODDLER KIT NOW

Si vous installez un "TODDLER KIT", passez à l'étape 15 et suivantes.

Se si sta montando un "TODDLER KIT", andare alla fase 15 e procedere da lì.

Si está colocando un "TODDLER KIT", vaya al paso 15 y siga desde allí.

Wenn Sie ein "TODDLER KIT" anbauen, fahren Sie von Schritt 15 fort.

 **16**

Optional tp 962 FIT DEN NOW

Si vous installez un "TENTE", passez à l'étape 16 et suivantes.



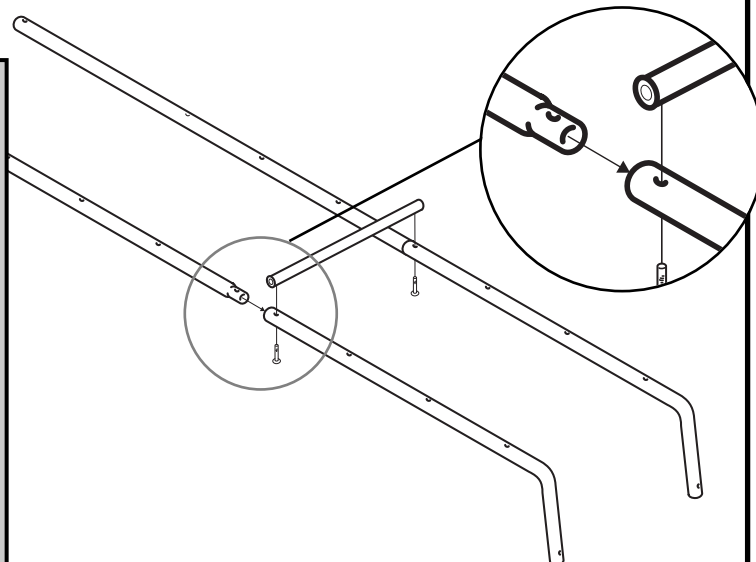

Se si sta montando un "TENDA", andare alla fase 16 e procedere da lì.

Si está colocando un "TOLDO", vaya al paso 16 y siga desde allí.

Wenn Sie ein "ZELT" anbauen, fahren Sie von Schritt 16 fort.



7

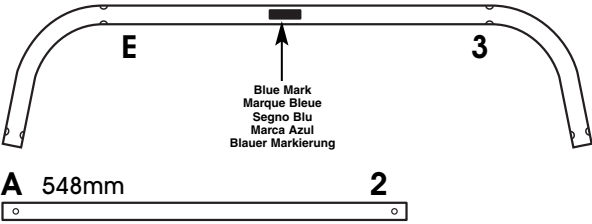

Bag 1		Bag 2	
PM 7246	FA 5174 M8	FA 7244 40mm	FA 7591 65mm
			
6	6	4	6

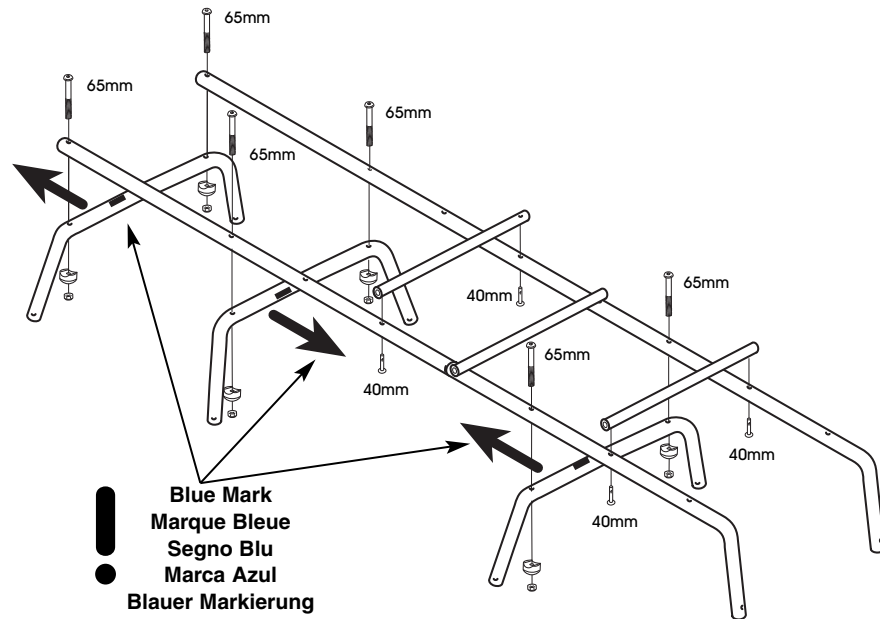

Blue Mark
Marque Bleue
Segno Blu
Marca Azul
Blauer Markierung



8

Bag 2	
FA 7560	FA 7244 40mm
	
4	4

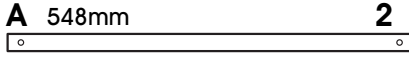

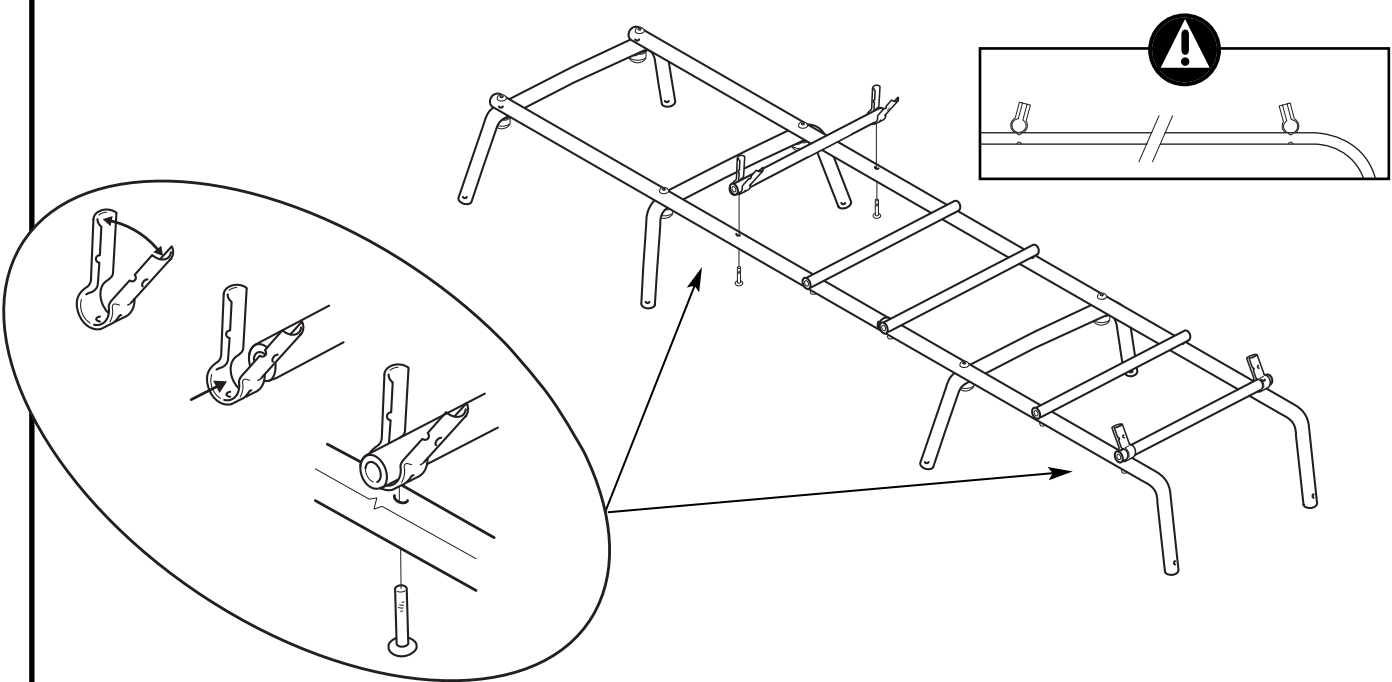

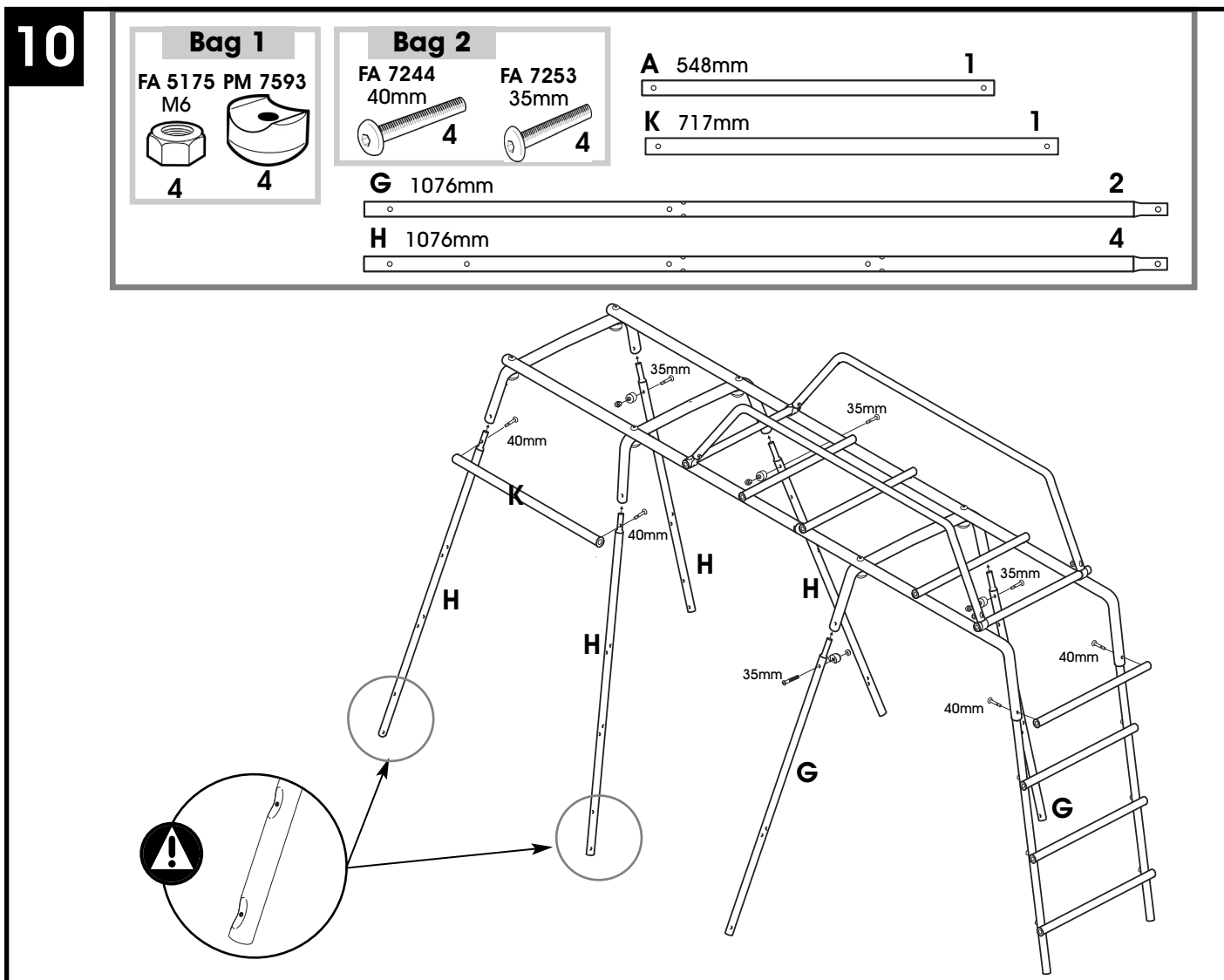
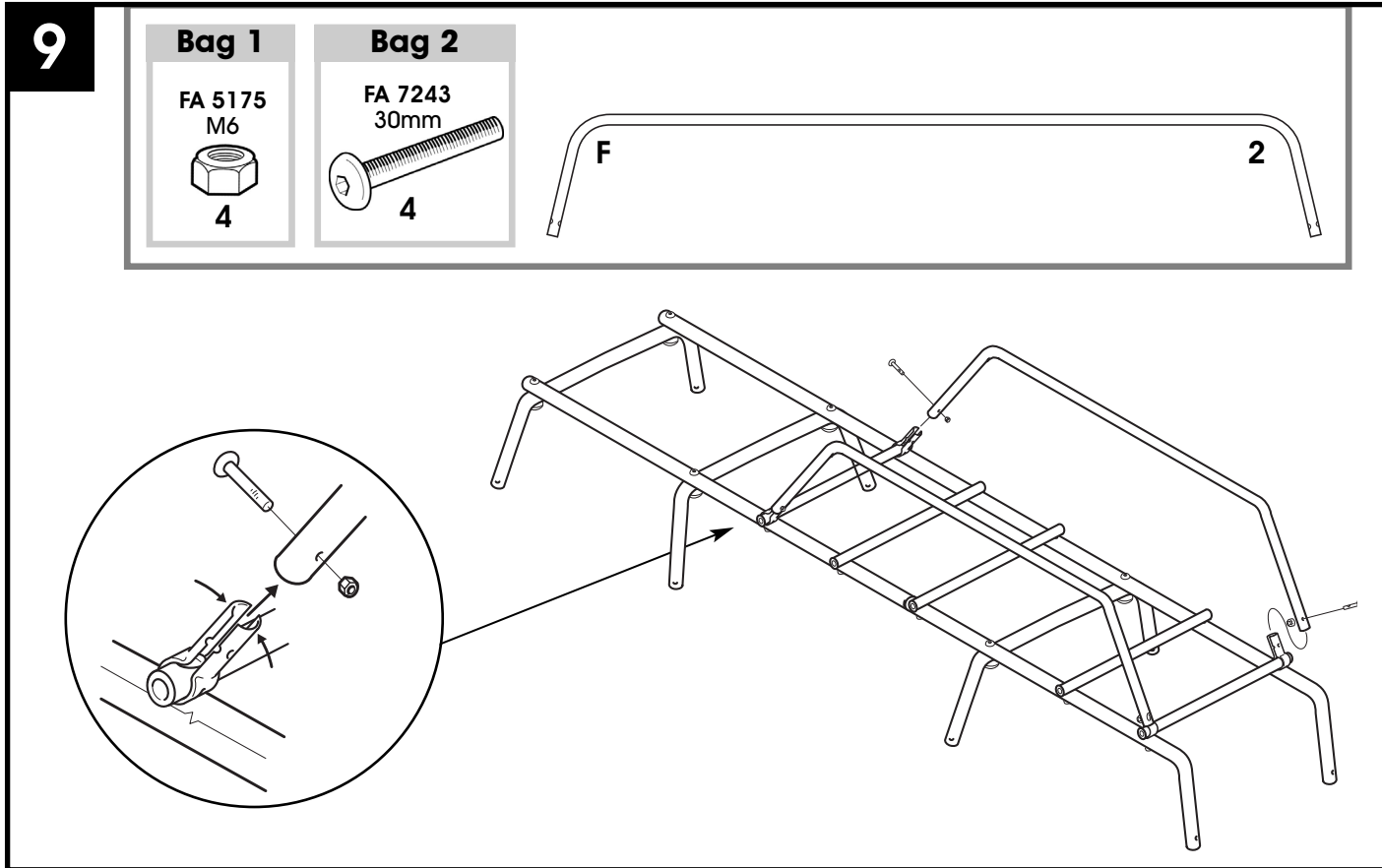

11

Bag 1

FA 5175
M6



2

Bag 2

FA 7244
40mm



6

FA 7245
55mm



2

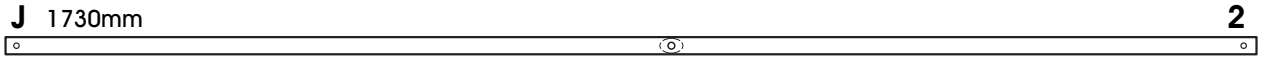

IMPORTANT PLEASE READ



21

Optional *tp 860*
FIT PLATFORMS NOW

Si vous installez un
"PLATFORMS", passez
à l'étape 21 et suivantes.

Se si sta montando un
"PLATFORMS", andare alla
fase 21 e procedere da lì.

Si está colocando un
"PLATFORMS", vaya al paso
21 y siga desde allí.

Wenn Sie ein "PLATFORMS"
anbauen, fahren
Sie von Schritt 21 fort.

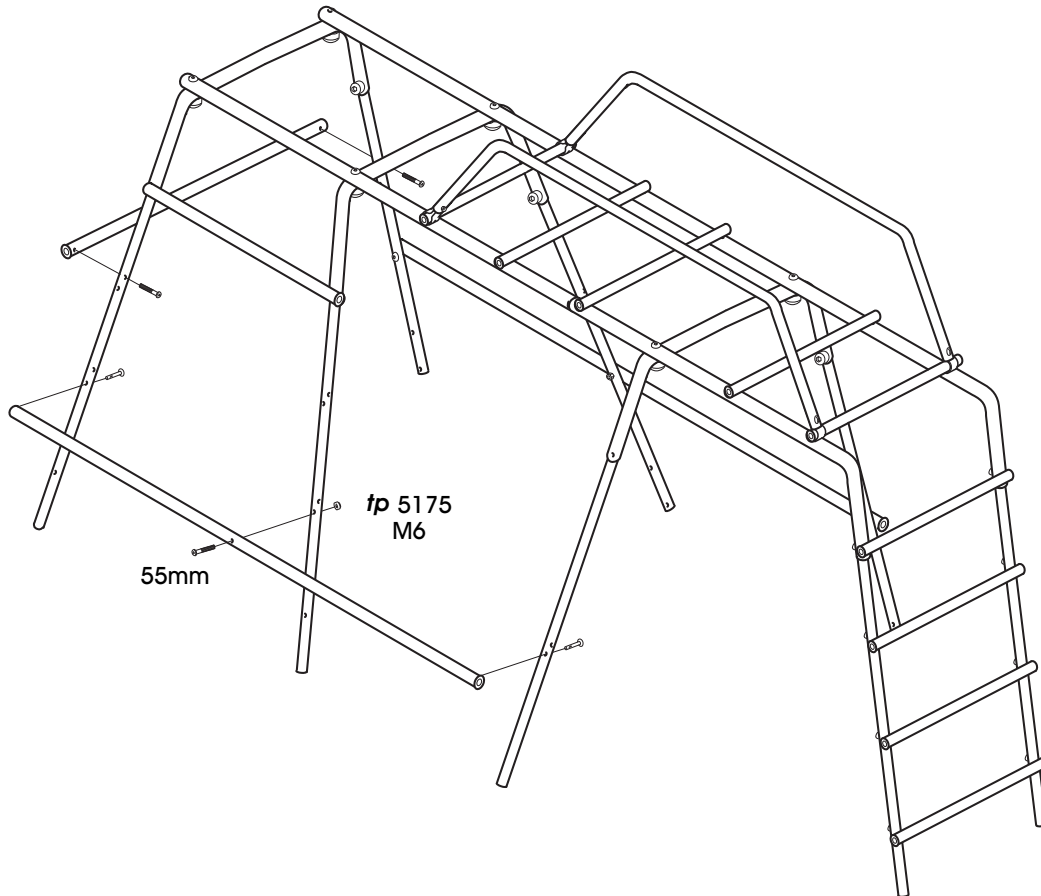

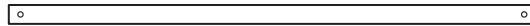
12**Bag 1**FA 7075
29mm**2****Bag 2**FA 7244
40mm**8****L** 797mm**2****M** 964mm**2****CHECK ALL BOLTS ARE FULLY TIGHTENED**

Assurez-vous que les écrous et les boulons sont serrés au maximum.

Controllare che tutti i dadi e i bulloni siano ben serrati.

Compruebe que todas las tuercas y tornillos estén ajustados completamente.

Prüfen Sie, dass alle Muttern und Bolzen fest angezogen sind.

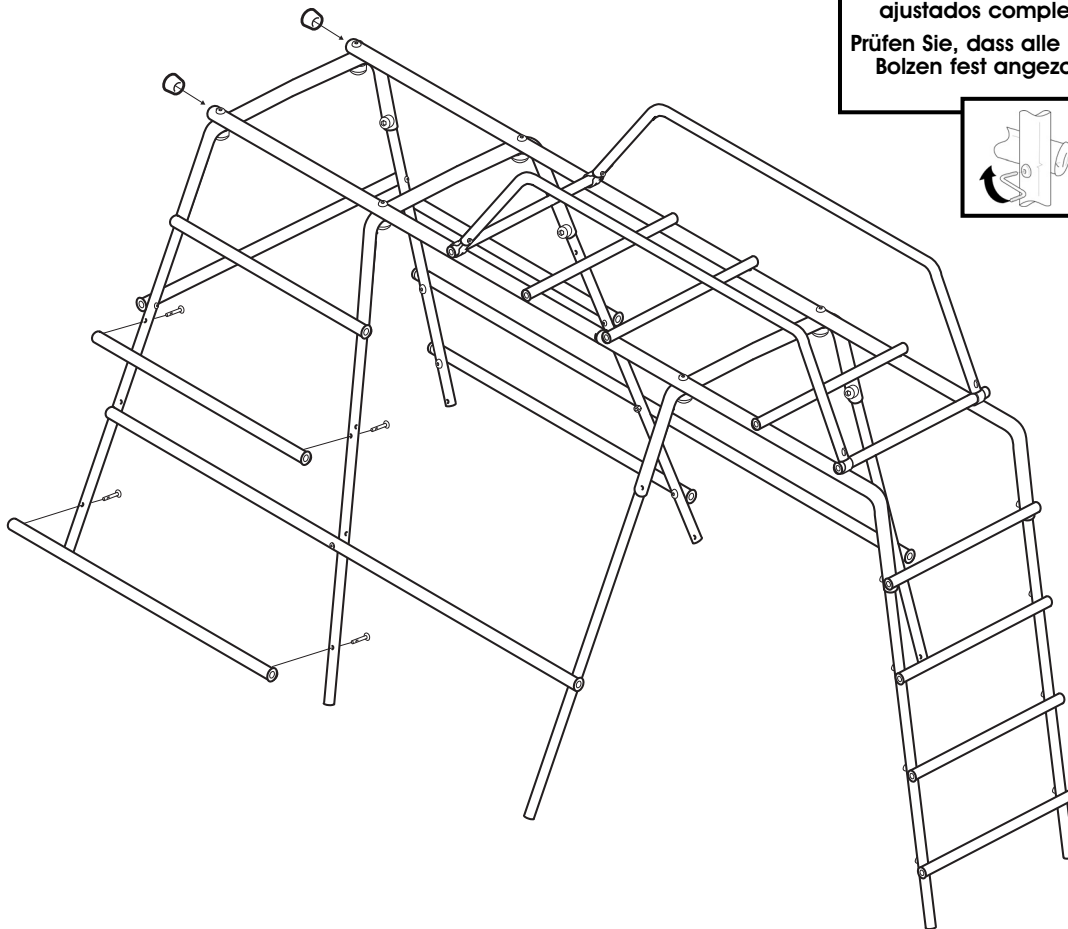
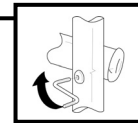

If you intend to use the frame at low height, the assembly is now complete. Apply petroleum jelly (Vaseline) or grease to the bottom of each leg (inside and out) and fit the 25mm ferrules.

Si vous avez l'intention d'utiliser le cadre à faible hauteur, le montage est à présent terminé. Appliquez du sel de pétrole (Vaseline) ou de la graisse au bas de chaque montant (intérieur et extérieur) et fixez les viroles de 25 mm.



Se si intende usare l'intelaiatura all'altezza bassa, l'assemblaggio è ora completo. Applicare vaselina o grasso all'interno e all'esterno della parte inferiore di ogni gamba e montarvi le ghiera da 25 mm.

Si se propone usar el armazón a baja altura, entonces ya está terminado el armado. Aplique jalea de petróleo (Vaseline) o grasa en la parte inferior de cada pata (por dentro y fuera) y coloque los regatones de 25 mm.

Wenn Sie den Rahmen mit niedriger Höhe benutzen wollen, ist der Aufbau jetzt beendet. Die Enden aller Beine mit Petrolat (z.B. Vaseline) oder Fett abschmieren (innen und außen) und 25-mm-Hülse anbringen.

15

13

Bag 3		Bag 4
FA 7111	PM 7038 22mm	FA 7242 16mm
		
8	8	8

510mm 8

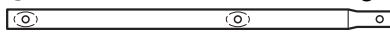

Extending the Frame to Full Height

Agrandissement du cadre à hauteur totale

Espansione dell'intelaiatura all'altezza completa



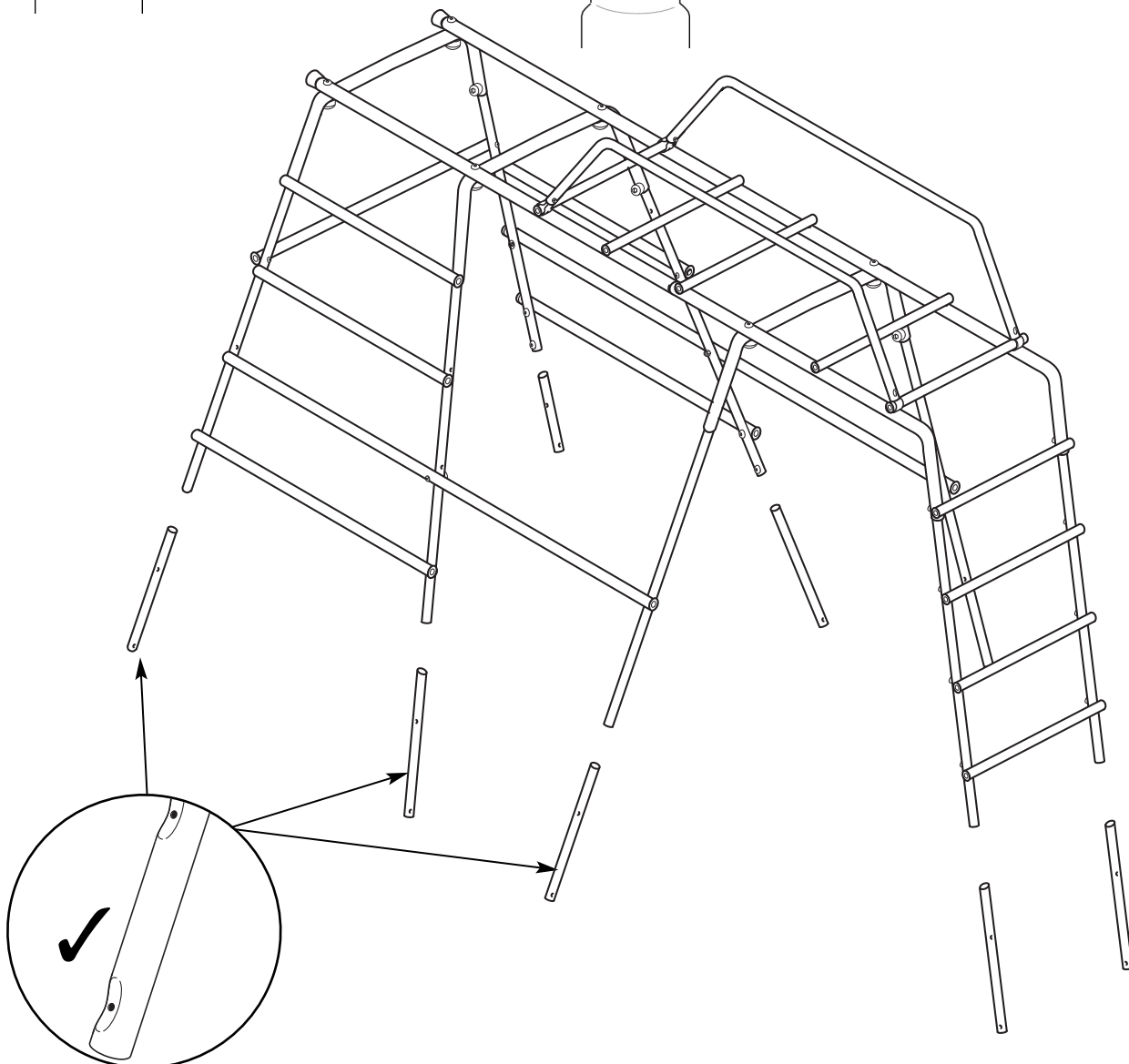
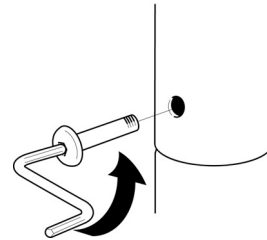
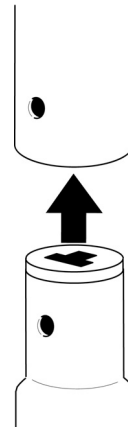
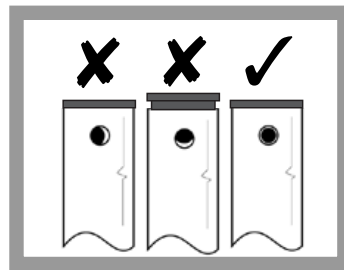
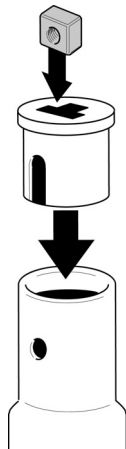

Expanding el armazón hasta su altura máxima

Rahmen auf volle Höhe ausbauen



16

14

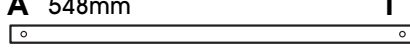
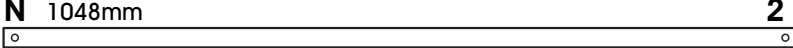
Bag 1 FA 7111 PM 7559 22mm  6	 2	Bag 2 PM 7592 25mm  4	Bag 4 FA 7244 40mm  6	FA 5290  6
A 548mm  1				
N 1048mm  2				

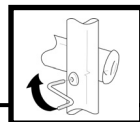
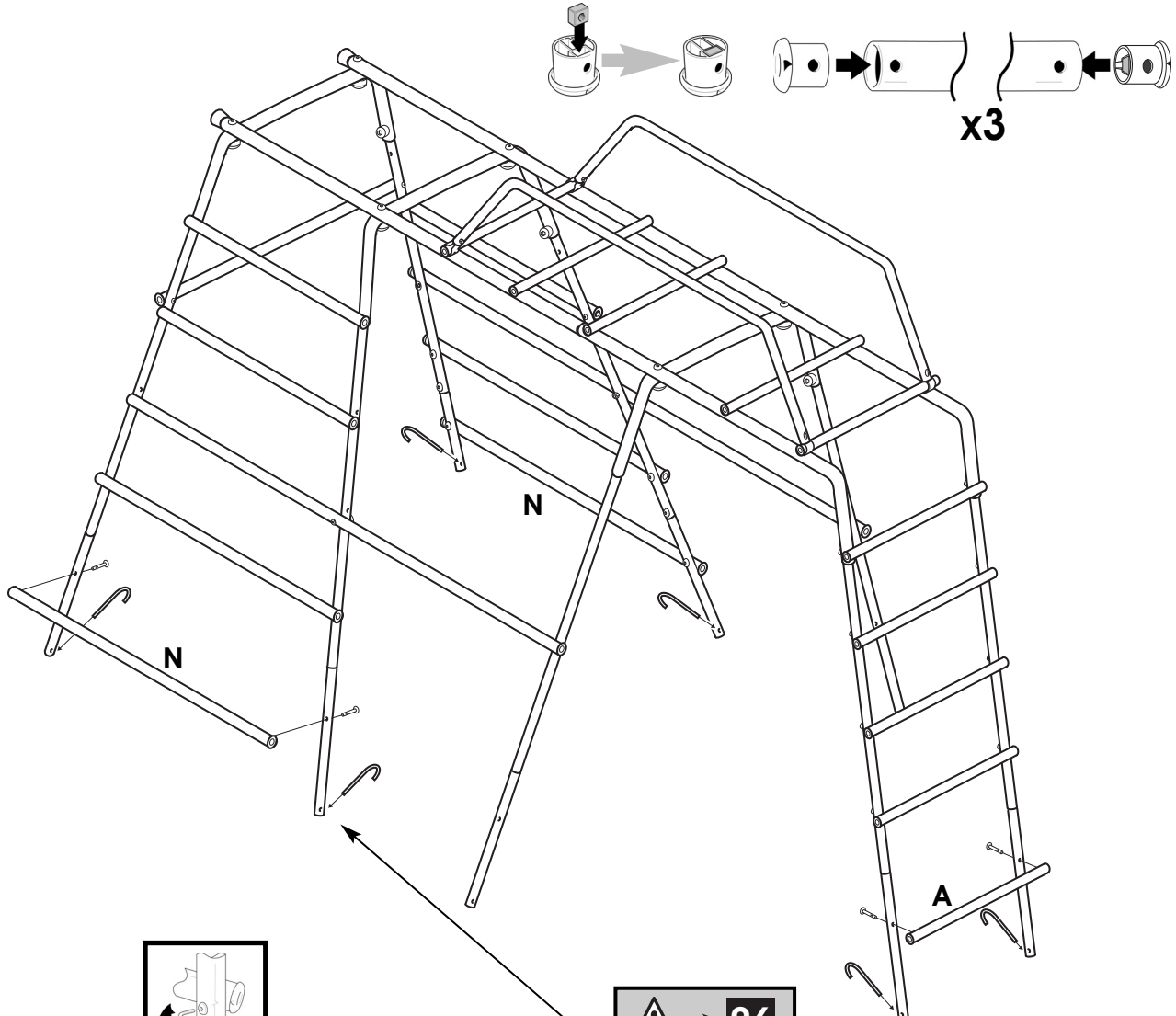

CHECK ALL BOLTS ARE FULLY TIGHTENED
 Assurez-vous que les écrous et les boulons sont serrés au maximum.
 Controllare che tutti i dadi e i bulloni siano ben serrati.
 Compruebe que todas las tuercas y tornillos estén ajustados completamente.
 Prüfen Sie, dass alle Muttern und Bolzen fest angezogen sind.

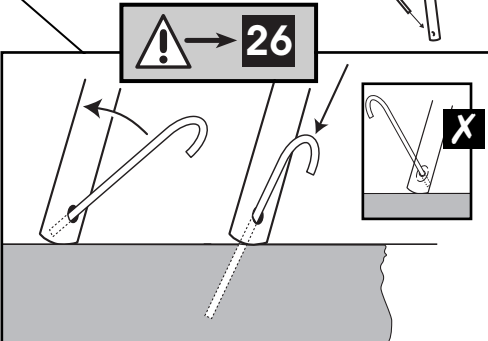

- Stakes**
- Les Piquets**
- Picchetti**
- Las Estacas**
- Bodenanker**

The assembly is now complete.
 Please ensure that maintenance and use instructions are followed and keep this booklet for future reference.
 Le montage est à présent terminé.
 Veuillez à suivre les instructions de maintenance et d'utilisation et conservez ce manuel pour référence ultérieure.
 L'assemblaggio è ora completo.
 Assicurarsi di seguire le istruzioni di manutenzione e d'uso, e conservare questo libretto per futuro riferimento.
 El armado ha terminado.
 Por favor compruebe que se sigan las instrucciones de mantenimiento y uso y conserve este folleto para consultarlo en el futuro.
 Aufbau ist jetzt fertig.
 Bitte sicherstellen, dass Wartungs- und Gebrauchsanweisungen befolgt werden. Für künftigen Gebrauch aufbewahren.

15

tp 850 Toddler kit

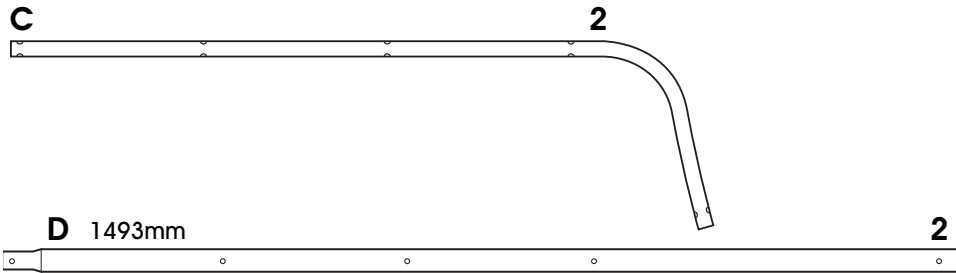
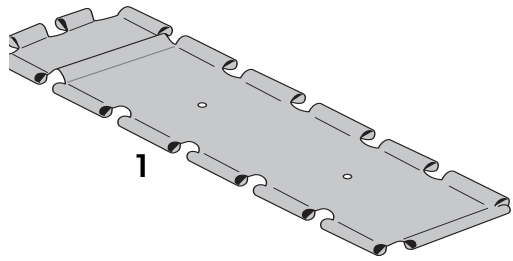

!
Optional
Option
Opzionale
Opcional
Zeltoption

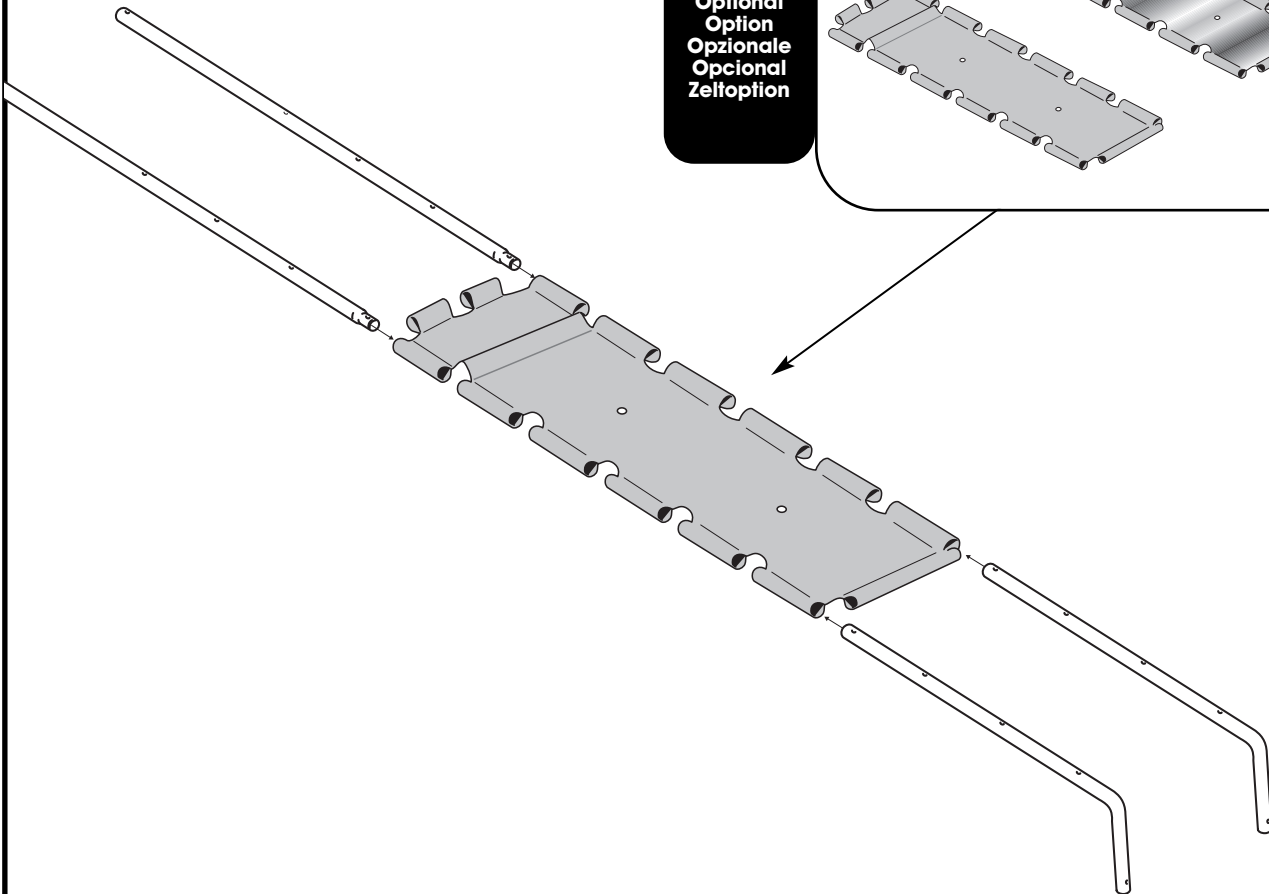
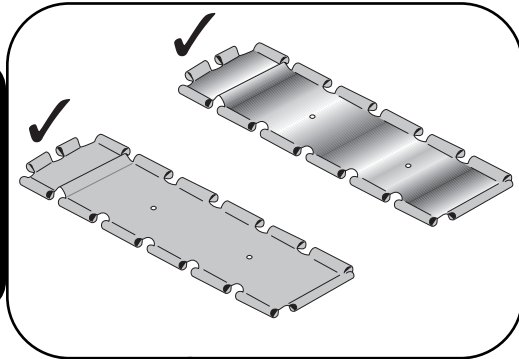

tp 962 Challenger Den

16

Bag 2

FA 7244
40mm

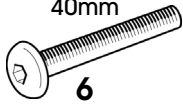

A 548mm

3

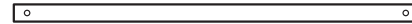

Den Box

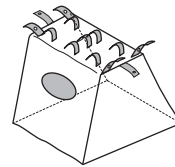

IMPORTANT PLEASE READ



Optional *tp 962*
FIT DEN NOW

Installez maintenant le
"DEN" facultatif.

Montare ora il "DEN"
opzionale.

Coloque el "DEN" opcional
en este paso.

Jetzt "DEN"
-Option einbauen.

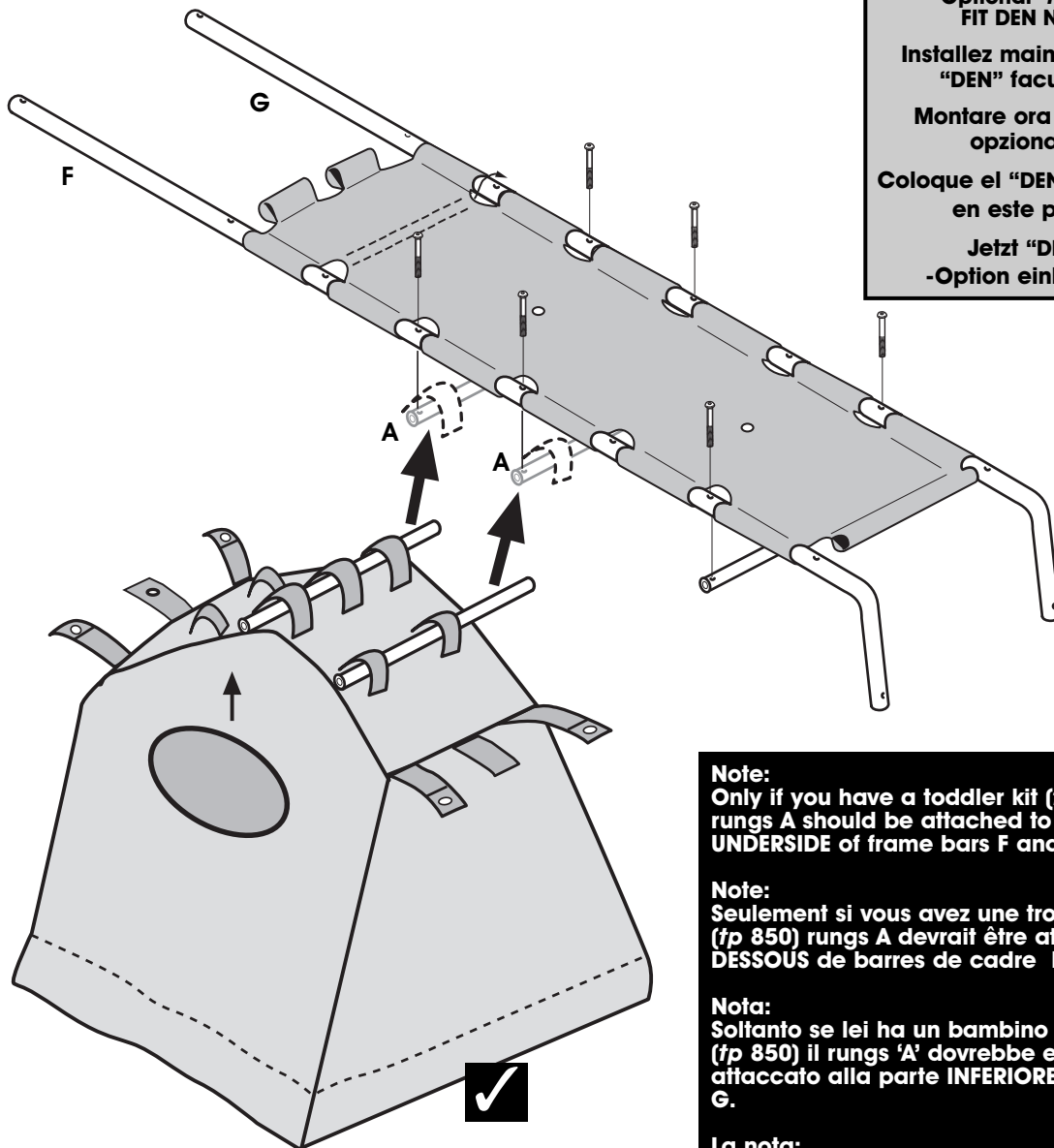

Note:
Only if you have a toddler kit (*tp 850*) fitted rungs A should be attached to the **UNDERSIDE** of frame bars F and G.

Note:
Seulement si vous avez une trousse de bébé (*tp 850*) rungs A devrait être attaché au **DESSOUS** de barres de cadre F et G.

Nota:
Soltanto se lei ha un bambino primi passi kit (*tp 850*) il rungs 'A' dovrebbe essere attaccato alla parte **INFERIORE** di sbarre F e G.

La nota:
Sólo si usted tiene un juego para pequeños (*tp 850*) rungs 'A' debe ser conectado a la **CARA INFERIOR** de barras F y G.

Bitte beachten:
Nur wenn Sie einen Klein-kindersatz (*tp 850*) gepasst rungs 'A' sollte zur **UNTERSEITE** von Rahmenstäben F und G befestigt werden.

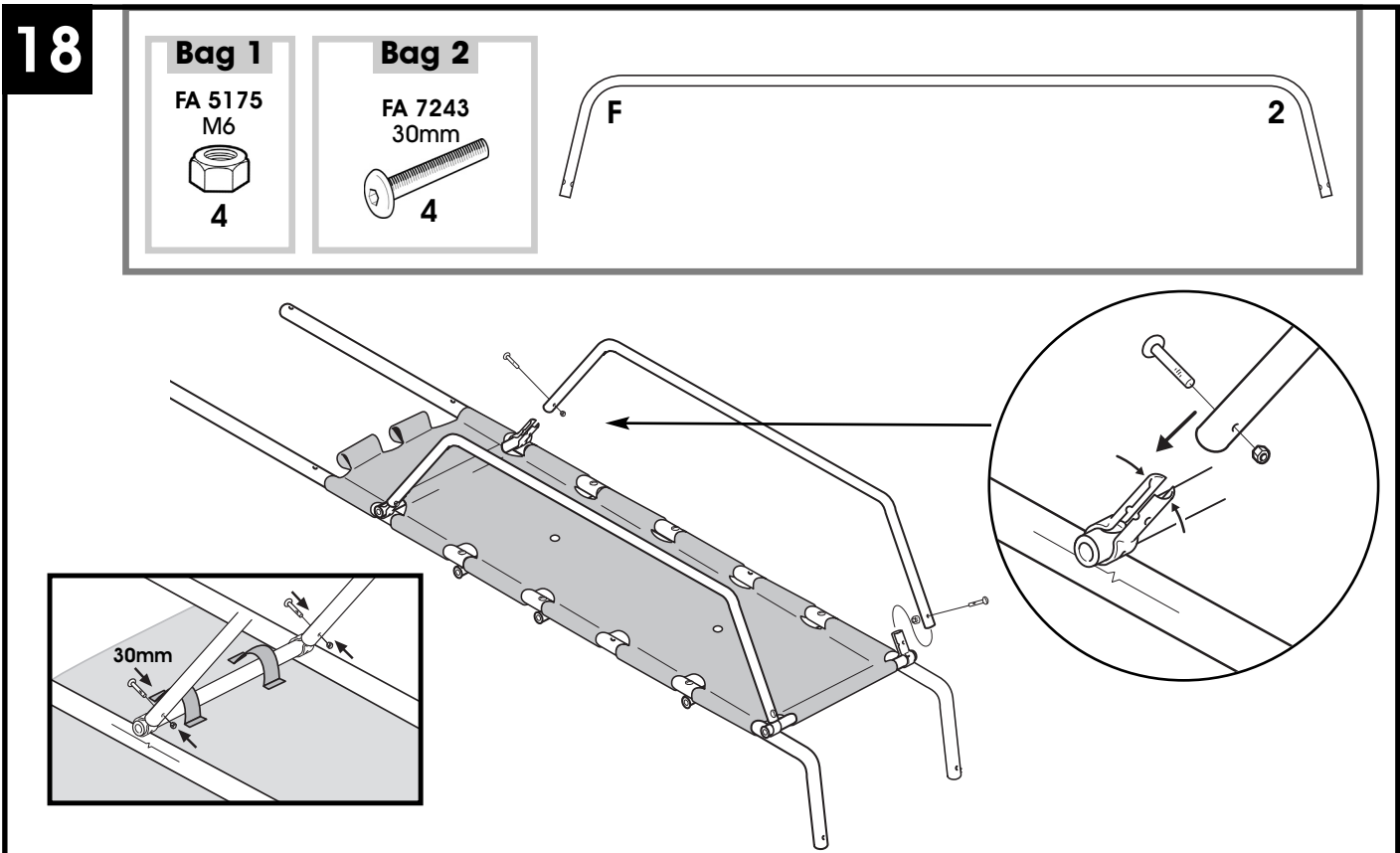
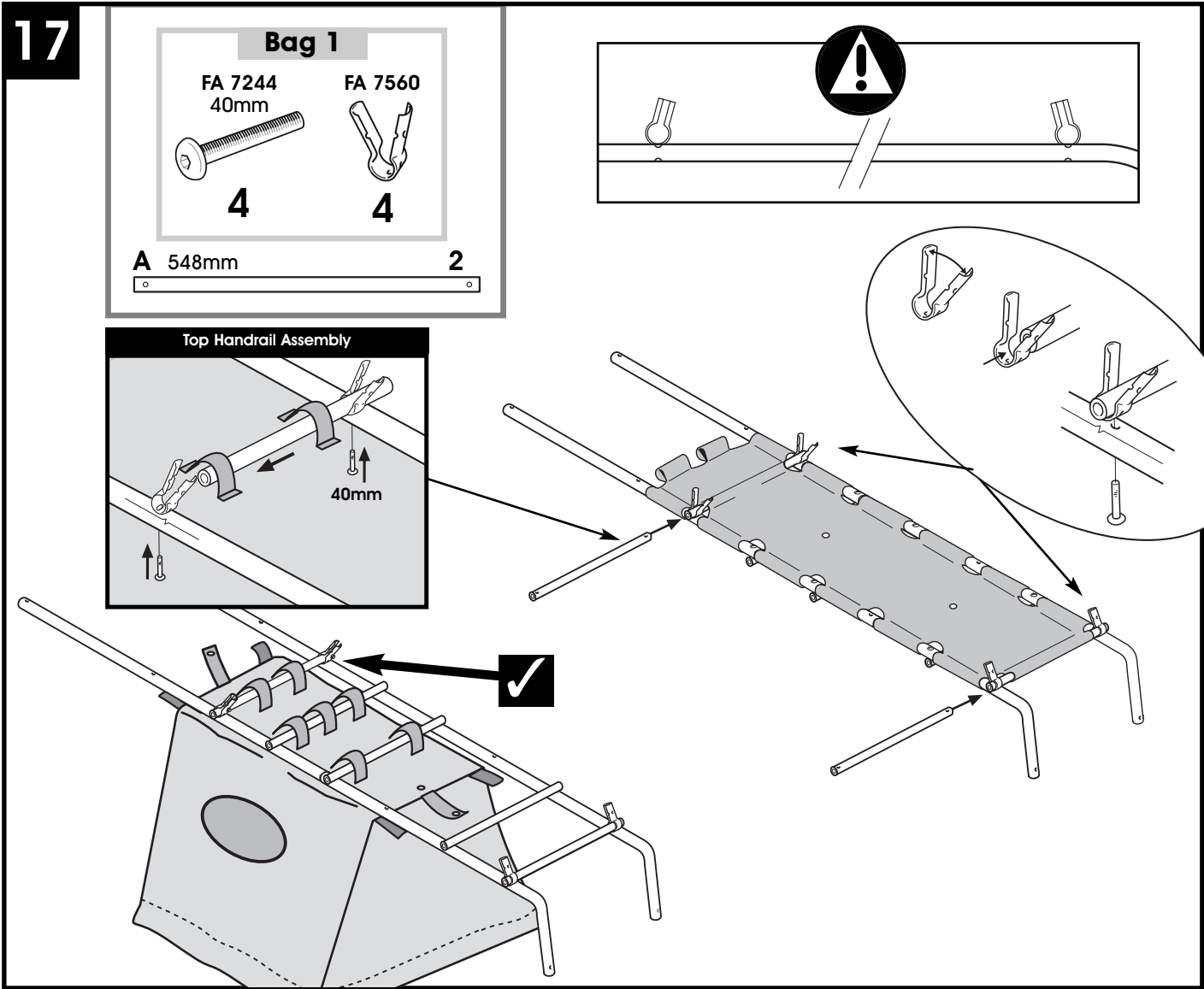

tp 860 Heavy Duty Challenger Platform

21

Bag 2
 FA 7244
 40mm



L 797mm **2**

L 943mm **1**



tp 860 Platforms Box

FA 7244 40mm **2**

FA 7111 **2**

PM 7592 **2**

L 943mm **1**

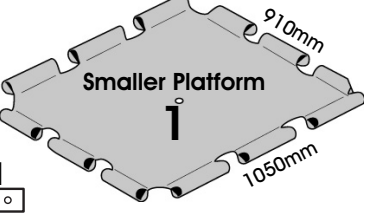
Smaller Platform
 910mm
 1050mm

Please note that the Toddler Kit and Den which you may have fitted is not shown in this, and some of the later stages. This is to allow a clearer view of the remaining assembly.

Veillez noter que le « Kit pour tout petit et Den » que vous avez peut-être installé n'est montré ni sur ce schéma ni dans les étapes suivantes. Le but est de pouvoir voir plus clairement le reste du montage.

Notare che, per consentire una più chiara visione del resto del gruppo, in questa fase e in quelle successive il 'Kit per bambini piccoli e Den', che può essere stato montato, non è illustrato.

Por favor observe que el Juego para pequeños y Den' que quizás haya colocado no aparece en este paso y los siguientes. Esto es a fin de permitir una vista más clara del armado restante.

Bitte beachten: Das von Ihnen eventuell angebaute "Kleinkinder-Satz und Den" wird hier und in folgenden Schritten nicht gezeigt, um den restlichen Zusammenbau deutlicher darzustellen.

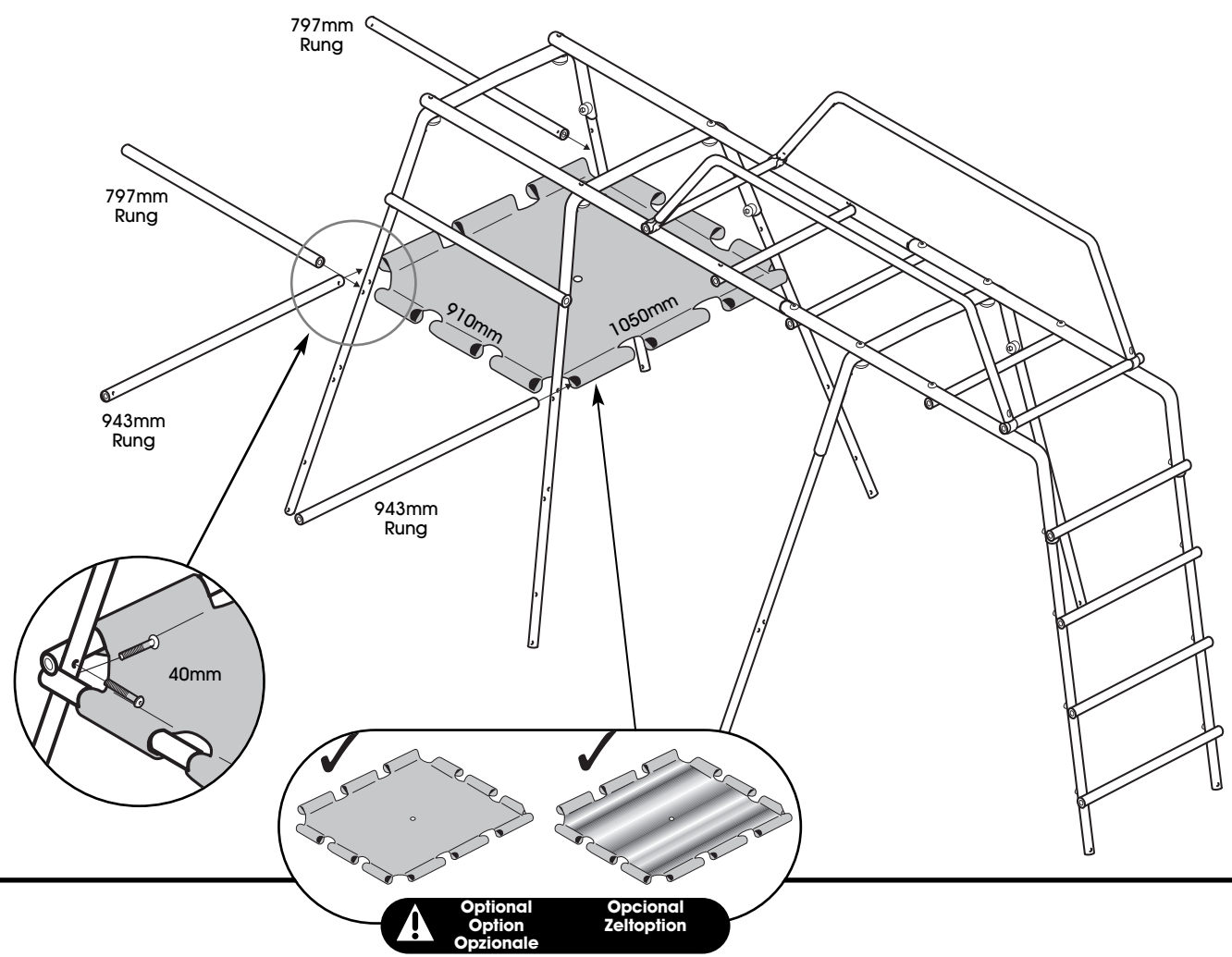
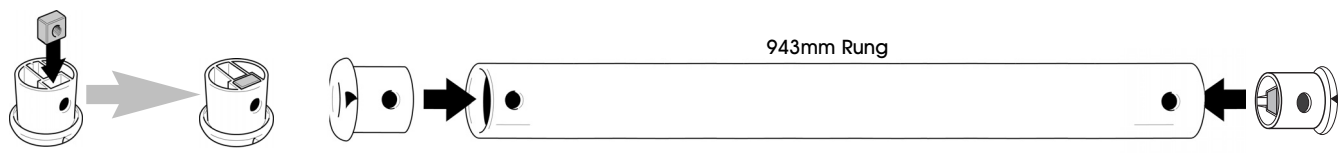

22

22

Bag 2

- FA 7244 40mm **4**
- FA 5175 M6 **2**
- FA 7245 55mm **2**

J 1730mm **2**

Platforms Box

- FA 7111 **4**
- PM 7031 25mm **4**
- FA 7244 40mm **4**

1048mm **2**

Larger Platform 1

1010mm
1155mm

 **23**

IF YOU ARE FITTING A DEN *tp 962*, GO TO STAGE 23 AND CONTINUE FROM THERE.
 Si vous installez un "DEN", passez à l'étape 23 et suivantes.
 Se si sta montando un "DEN", andare alla fase 23 e procedere da lì.
 Si está colocando un "DEN", vaya al paso 23 y siga desde allí.
 Wenn Sie ein "DEN" anbauen, fahren Sie von Schritt 23 fort.

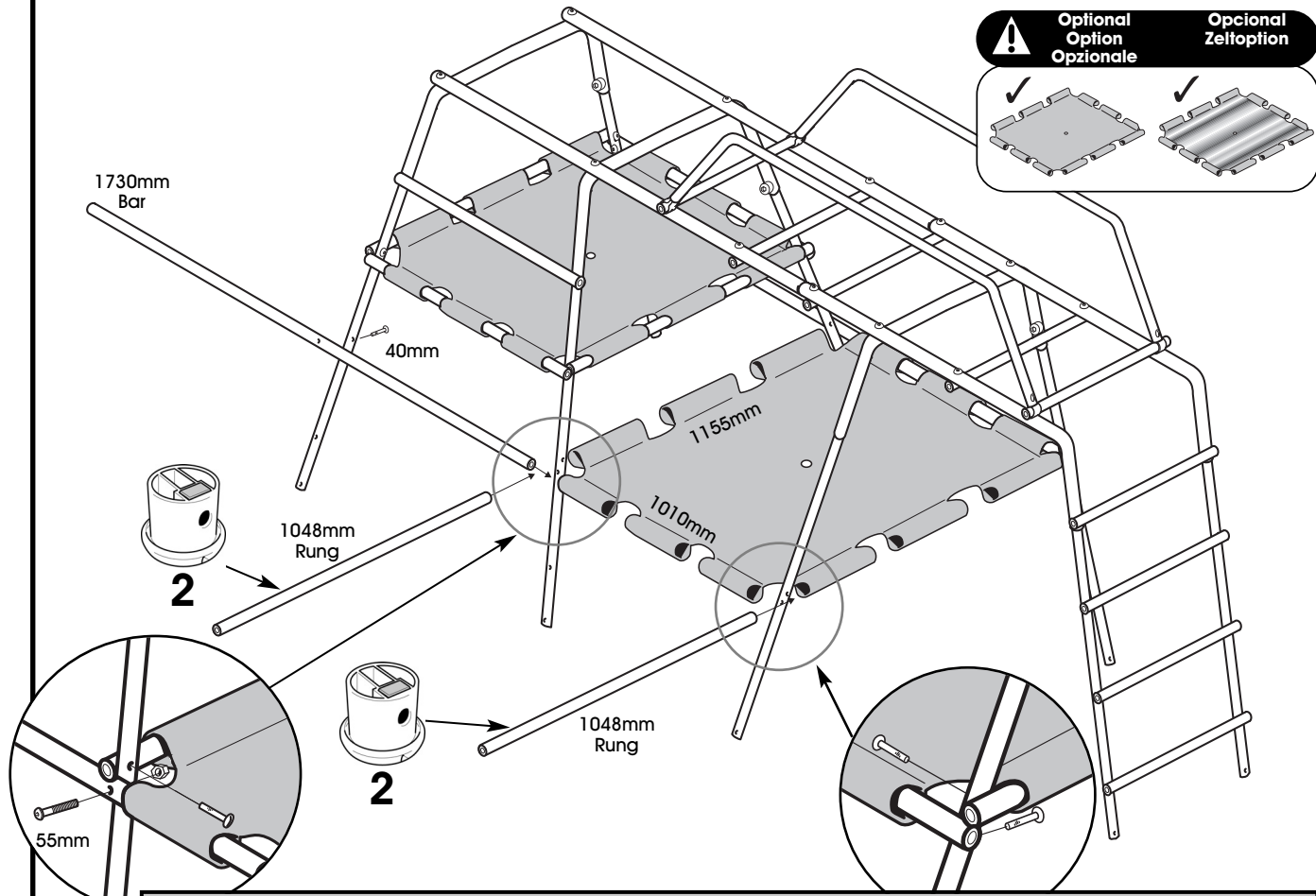

 **24**

IF YOU ARE NOT FITTING A DEN *tp 962*, GO TO STAGE 24 AND CONTINUE FROM THERE.
 Si vous n'installez pas de "DEN", passez à l'étape 24 et suivantes.
 Se non si sta montando un "DEN", andare alla fase 24 e procedere da lì.
 Si no está colocando un "DEN", vaya al paso 24 y siga desde allí.
 Wenn Sie kein "DEN" anbauen, fahren Sie von Schritt 24 fort.

23

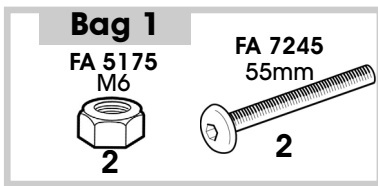

J 1730mm

2

Platforms Box

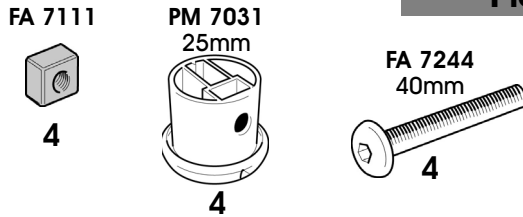

1048mm

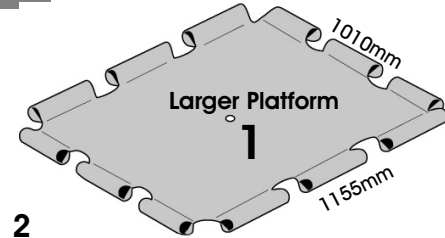

2

The Den which you started fitting in stage 16 is now shown again. Note how the platform and tent loops are alternately slid onto the bar (any remaining tent loops should be tucked inside the tent).

Vous pouvez de nouveau voir la tente que vous avez commencée à monter à l'étape 16. Veuillez noter la façon dont la plateforme et les boucles de la tente se glissent en alternance sur la barre (toute boucle de tente restante doit être rentrée à l'intérieur de la tente).

Viene ora mostrata nuovamente la tenda che si è cominciato a montare nella fase 16. Notare come i cappi della piattaforma e della tenda vengono fatti scivolare alternativamente sulla barra (ripiegare dentro la tenda ogni rimanente cappio della tenda).

El toldo que comenzó a colocar en el paso 16 vuelve a ser mostrado. Observe cómo se deslizan la plataforma y los lazos del toldo alternadamente sobre la barra (si queda algún lazo restante, debería ser metido dentro del toldo).

Das von Ihnen in Schritt 16 begonnene Zelt erscheint jetzt wieder. Bitte beachten, wie die Schlaufen der Plattform und des Zelts wechselseitig auf die Stange geschoben werden (restliche Zeltschlaufen ins Zelt einstecken).

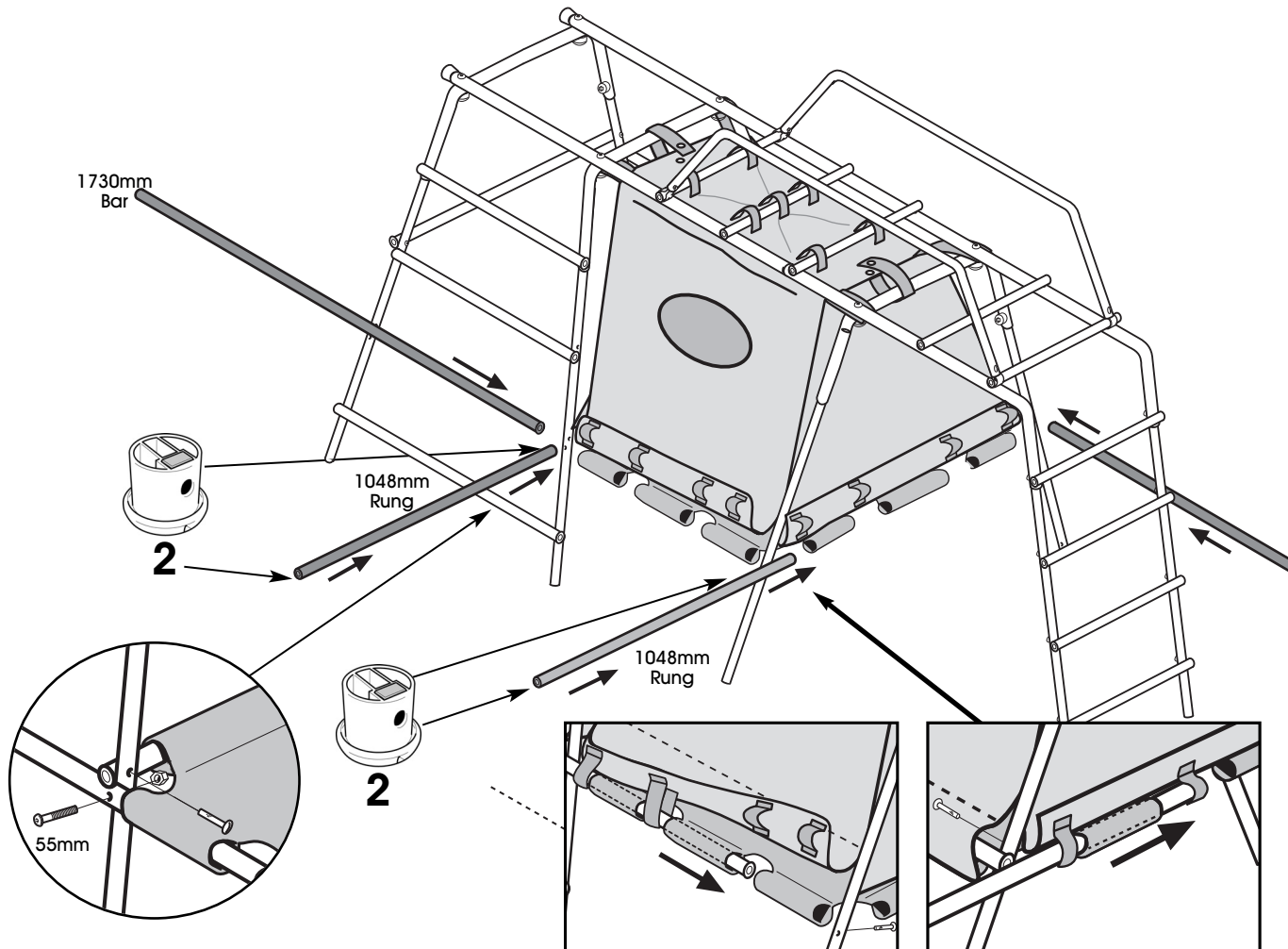

24

Bag 1

PM 7075
29mm



2

Bag 2

FA 7244
40mm



4

M 964mm

2

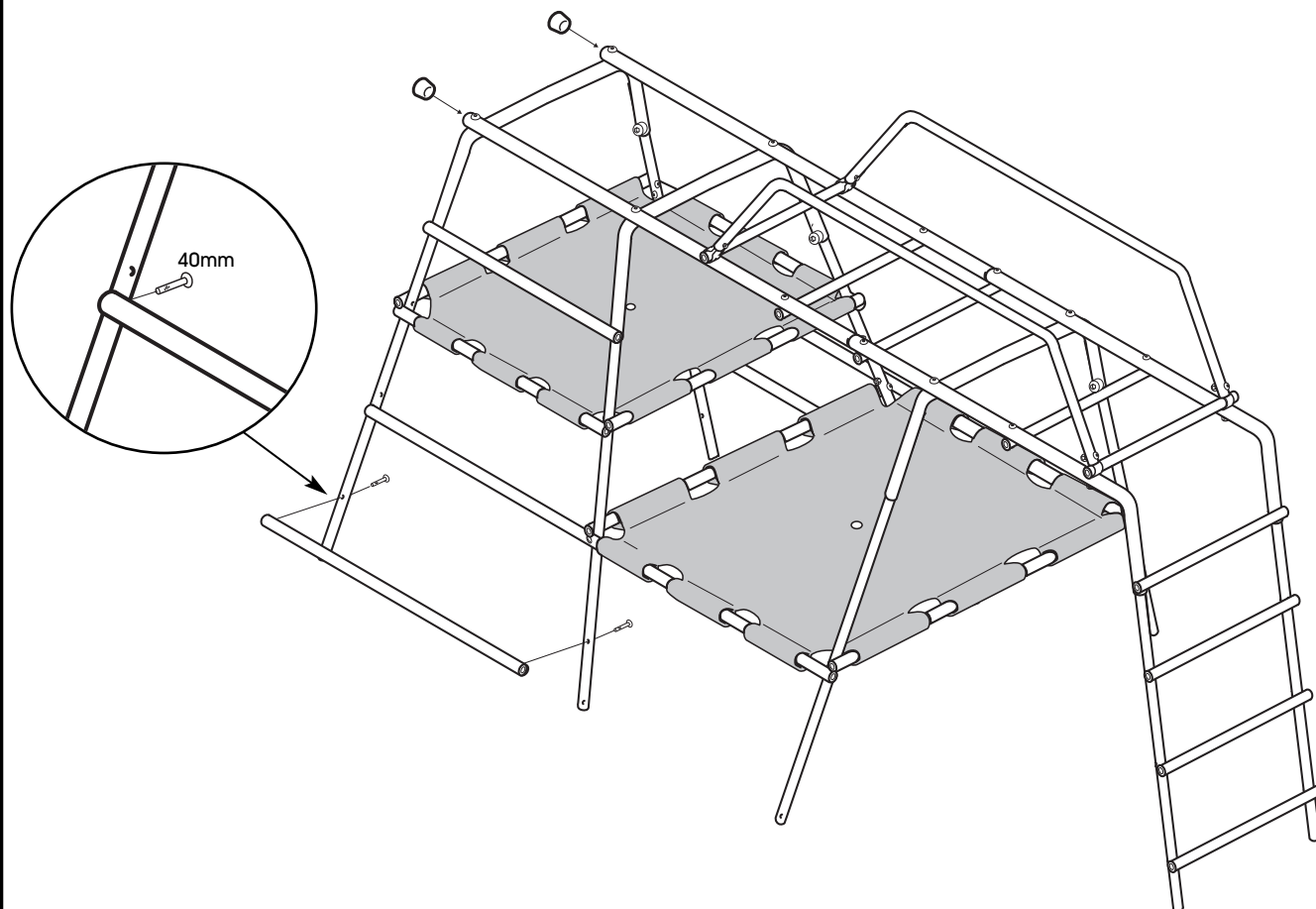

If you intend to use the frame at low height, the assembly is now complete. Apply petroleum jelly (Vaseline) or grease to the bottom of each leg (inside and out) and fit the 25mm ferrules

Si vous avez l'intention d'utiliser le cadre à faible hauteur, le montage est à présent terminé. Appliquez du sel de pétrole (Vaseline) ou de la graisse au bas de chaque montant (intérieur et extérieur) et fixez les viroles de 25 mm.

Se si intende usare l'intelaiatura all'altezza bassa, l'assemblaggio è ora completo. Applicare vaselina o grasso all'interno e all'esterno della parte inferiore di ogni gamba e montarvi le ghiera da 25 mm.

Si se propone usar el armazón a baja altura, entonces ya está terminado el armado. Aplique jalea de petróleo (Vaselina) o grasa en la parte inferior de cada pata (por dentro y fuera) y coloque los regatones de 25 mm.

Wenn Sie den Rahmen mit niedriger Höhe benutzen wollen, ist der Aufbau jetzt beendet. Die Enden aller Beine mit Petrolat (z.B. Vaseline) oder Fett abschmieren (innen und außen) und 25-mm-Hülse anbringen.

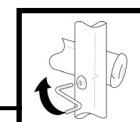

CHECK ALL BOLTS ARE FULLY TIGHTENED

Assurez-vous que les écrous et les boulons sont serrés au maximum.

Controllare che tutti i dadi e i bulloni siano ben serrati.

Compruebe que todas las tuercas y tornillos estén ajustados completamente.

Prüfen Sie, dass alle Muttern und Bolzen fest angezogen sind.



Extending the frame to full height. Return to stage 13.

Agrandissement du cadre à hauteur totale. Retournez à l'étape 13.

Estensione dell'intelaiatura all'altezza completa. Tornare alla fase 13.

Extendiendo el armazón hasta su altura máxima. Regrese al paso 13.

Rahmen auf volle Höhe ausbauen. Zurück zu Schritt 13.

25

PLAN VIEW OF CHALLENGER2 AND ACCESSORIES

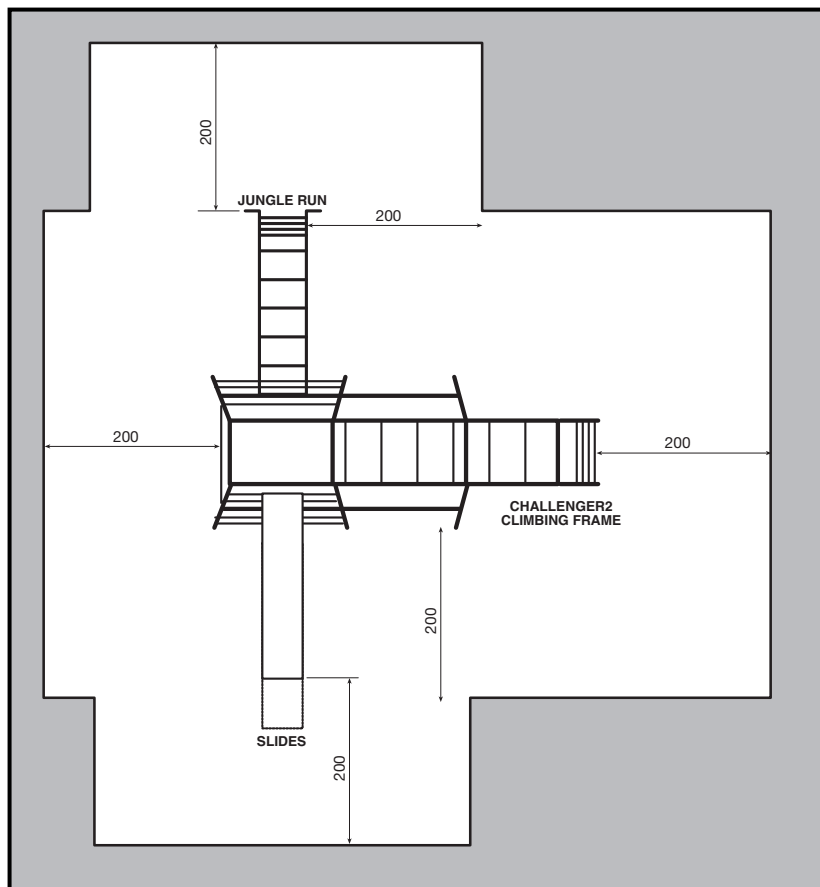

All Dimensions in Centimetres

Challenger2 Frame	TP 912
2.42m Slide Attachment	TP 204
3m Slide Attachment	TP 202
Jungle Run	TP 837

(Product subject to change.
Please check with your local stockist.)

The Safe Play Area refers to the zone extending 2m beyond the play set on all sides, including the space above the apparatus.

Additional accessories may increase the size of the Safe Play Area.

The ground surface must be level. Installing your playset on sloping ground can cause it to lean or 'rack'. This puts additional stress on all the connections and joints and in time will cause them to fail.

The Safe Play Area must be free from all structures, landscaping, trees and branches, rocks, wires, sprinkler heads and other similar obstacles to safe play. Children can be seriously injured running or swinging into these obstacles.

Aire de sécurité recommandée:

L'aire de sécurité se réfère à la zone située dans un rayon de 2 m tout autour du jeu, y compris l'espace situé au-dessus de ce dernier.

L'ajout d'accessoires est susceptible d'étendre cette aire de sécurité.

La surface au sol doit être bien plane. Installé sur un terrain en pente, ce jeu pourra pencher ou s'endommager. Les composants seront alors soumis à des tensions plus importantes, ce qui risque de diminuer leur durée de vie.

L'aire de sécurité ne doit pas comporter de structures, aménagements paysagers, arbres et branches, pierres, câbles, têtes d'arrosage ou autres obstacles susceptibles d'empêcher les enfants de jouer en toute sécurité. Les enfants pourraient heurter ces obstacles en courant ou en se balançant et ainsi se blesser grièvement.

Area di gioco sicura raccomandata:

L'Area di giuoco sicura si riferisce alla zona che si estende per 2 m su tutti i lati oltre l'insieme da gioco, incluso lo spazio al di sopra dell'apparato.

Gli accessori aggiuntivi possono estendere le dimensioni dell'Area di gioco sicura.

La superficie del terreno deve essere in pari. Installando l'insieme da gioco sul terreno in pendenza, può inclinarsi o 'stirarsi'. Ciò sottoporrebbe tutti i componenti a sforzo addizionale, e potrebbe comprometterne la durata.

L'Area di gioco sicura deve essere libera da strutture, variazioni del terreno, alberi e rami, pietre, fili metallici, testine per annaffiare e tutto quanto esporrebbe a rischio la sicurezza del gioco. Correndo contro questi ostacoli, o urtandovi durante l'oscillazione, i bambini potrebbero ferirsi seriamente.

25A

Área Segura de Juego recomendada:

El Área Segura de Juego se refiere a la zona que se extiende hasta 2m desde los juegos todo alrededor, incluyendo el espacio encima del aparato. Accesorios adicionales pueden aumentar el tamaño del Área Segura de Juego. La superficie del suelo debe ser uniforme. Si instala sus juegos sobre un terreno con declive, hará que se inclinen o se "arruinen". Esto coloca tensión adicional sobre todos los componentes y puede acortar su vida útil. El Área Segura de Juego debe estar libre de todo tipo de estructuras, arquitectura paisajista, árboles y ramas, rocas, cables, boquillas de aspersores y cualquier otro elemento que pueda obstaculizar el juego seguro. Los niños pueden herirse gravemente con estos obstáculos al correr o columpiarse.

Empfohlene sichere Spielfläche:

Die sichere Spielfläche erstreckt sich an allen Seiten 2 m über das Spielgerät hinaus, einschließlich Raum über dem Gerät. Zubehör kann die sichere Spielfläche erweitern. Der Boden muss eben sein. Wenn Sie das Spielgerät auf einem Hang installieren, kann es sich lehnen oder verziehen. Dadurch werden alle Teile zusätzlicher Last ausgesetzt, was zu verkürzter Lebensdauer führen kann. Im sicheren Spielraum darf sich nichts befinden, das sicheres Spielen behindern könnte wie z.B. Aufbauten, Gärten, Bäume oder Büsche, Steine, Draht, Rasensprinkler oder ähnliches. Wenn Kinder in solche Hindernisse hineinlaufen oder -schaukeln, können sie sich schwer verletzen.

26

Ground Stakes

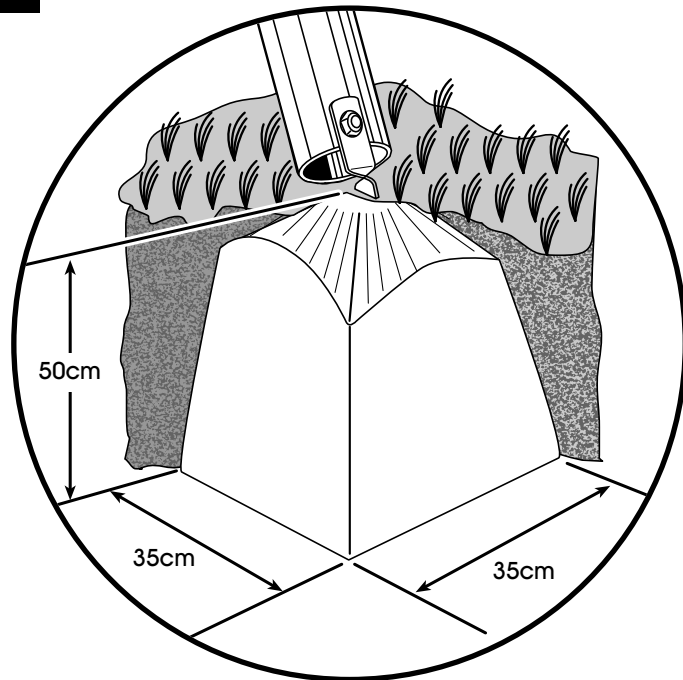

- Set the stakes in concrete (as shown).
- **Never set the legs of the frame in concrete.**
- Fixez les poteaux dans le béton comme cela est montré.
- **Ne fixez jamais les pieds du cadre dans le béton.**
- Fissare i paletti nel calcestruzzo come illustrato.
- **Non fissare mai le gambe dell'intelaiatura nel calcestruzzo.**
- Puede colocar las estacas sobre hormigón del modo indicado.
- **Pero nunca coloque las patas del armazón sobre hormigón.**
- Können Sie die Pfähle einzementieren, siehe Abbildung.
- **Die Rahmenstangen dürfen nicht einzementiert werden.**

Register your new TP product on-line now at www.tptoys.com/productregistration

For a chance to win £200 of TP products in our next quarterly on-line guarantee registration draw. Immediate access to TP products updates and offers.

TERMS AND CONDITIONS

Each quarter one prize of £200 worth of TP products will be won. Your on-line purchase registration will be entered in the next available quarterly draw only. Postal registrations will not be included. No cash alternative is available in any circumstances. Open to all TP purchasers who are aged over 18 years who register their new TP product on-line except employees of TP Activity Toys. The winners will be notified in writing within four weeks of the draw. No correspondence will be entered into. A list of winners is available on request 6 weeks after every draw by contacting TP at the address given below. TP Activity Toys reserve the right to alter, amend, or otherwise change the terms of the Prize Draws in the interest of the consumer without prior notification. This promotion is being run by TP Activity Toys (Tube Plastics Ltd), Severn Road, Stourport on Severn, Worcestershire DY13 9EX

Alternatively, complete the form opposite and place in an envelope addressed to TP Activity Toys, Severn Road, Stourport on Severn, DY13 9EX England. Please remember a stamp. Remember however, that you must register on-line to enter our prize draw.

Data Protection

TP will not pass your personal information to anyone else. If you would like to receive information on TP please tick the appropriate box.

- by email
 by post

Product Registration Form

Mr. Mrs. Miss Ms

First name:..... Surname:

E-mail:

Address:

.....Postcode:

Tel:

Product(s) purchased..... TP Product no. No of children:

..... TP Dates of birth:

..... TP
 TP
 TP

..... TP

Name of retailer:..... Date of Purchase:



Lifetime Guarantee

Thank you for purchasing one of our quality climbing frames. The product carries a **Lifetime Guarantee** against rust causing failure on the galvanised steel frame.



Freedom to play

TP Activity Toys guarantees to you, the original retail purchaser, that for your children's lifetime of play rust will not cause the product to fail structurally. (Failure is defined as rusting from the inside through to the outside ie perforation.) In the event of purchase of the trampoline for adult use (either exclusively or in conjunction with use by children), the lifetime guarantee is defined as ten years from the date of purchase. In the unlikely event that such rusting occurs, TP will either supply replacement parts of the affected area, or replace the trampoline if the parts are no longer available.

Galvanised products are very tough but they may require maintenance from time to time (as detailed in the maintenance notes at the front of this handbook.) Regular inspections are important. Any surface rust, staining etc should be treated in accordance with these instructions and are not covered by the **Lifetime Guarantee**.

The TP Star Trampoline Range also includes a five year guarantee on beds and pads. All other components including surround enclosures are covered by a one year guarantee.

The Guarantee does not apply to any part if damage has been caused by abuse, vandalism, misuse, accident or non-maintenance or if the original purchaser resides outside the United Kingdom and Republic of Ireland. For purchasers living outside the United Kingdom or Republic of Ireland, all components are covered by a one year guarantee.

To be covered by this **Guarantee** it is essential that you complete and return one **Guarantee Registration**,

listing all products purchased. As an additional bonus you will then automatically be entered into the **Quarterly Prize Draw**.

This helps us to monitor and maintain our performance as market leaders in the design and manufacture of outdoor play and associated products. It also helps us to communicate quickly with you should the need arise and to keep you up to date with the developments in our range.

"This guarantee does not affect your legal rights."

Claim Procedure

Should a claim be necessary please write to our Customer Services Department, TP Activity Toys., Stourport-on-Severn, Worcestershire, DY13 9EX, England.

We would require the following information and we recommend that you complete some of these details now:

- Your name, address and daytime/evening telephone number.**
- Product Name.**
- Guarantee Number.**
- Date of Purchase.**
- Where Purchased.**
- Original Till Receipt.**
- Identification of the Affected Part(s) - Photographs preferable.**

Please do not send products or parts at this stage as this may not be necessary.

This Guarantee Number is:

TP

Designed in the UK by **TP Activity Toys** (Tube Plastics Ltd), Severn Road, Stourport on Severn, Worcestershire, DY13 9EX, England.
Made in China.

Customer Service:
Email: customerservices@tp toys.com
Website: www.tptoys.com

Spare Parts +44 (0) 1299 872803
Technical Helpline +44 (0) 1299 872804

tp Part No: In7594 Issue A 05 09



Register your new TP product on-line now at www.tptoys.com/productregistration



Freedom to play

- For a chance to win £200 of TP products in our next quarterly on-line product registration draw.
- Immediate access to TP products updates and offers.

Full terms and conditions overleaf

This Guarantee Number is:

TP

