

mothercare



polka
twin stroller

user guide

IMPORTANT. KEEP FOR
FUTURE REFERENCE

1

introduction

This narrow twin stroller has reclining backrests for babies from birth, lockable swivel wheels for manoeuvrability, two baskets each for carrying up to 2kg of shopping and baby items, evenly distributed.

A hood and raincover are also included for weather protection.

The recommended weight limit for each seat is 15kg.

2

preparation for use

opening

1

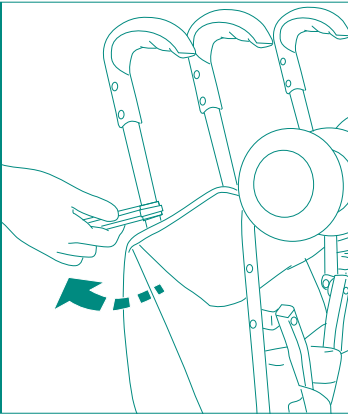

Release the **folding** catch.

2

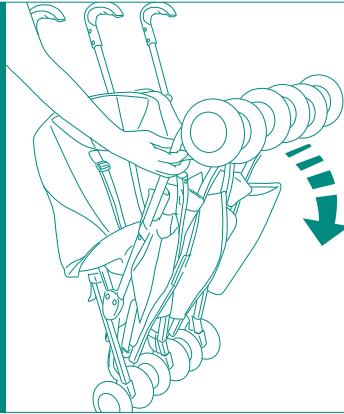

Push the front wheels down.

3

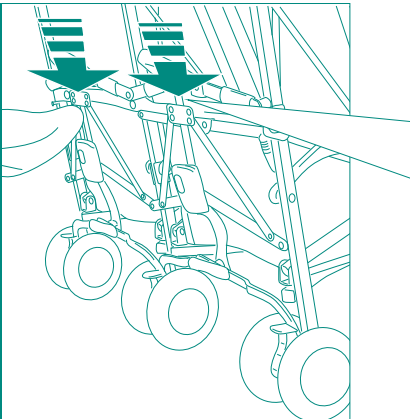

Push down on the locking bars until straight.

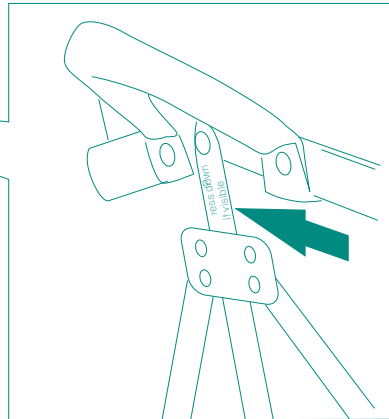

The words "Press down if visible" on the vertical bar must not be visible while the stroller is in use.

1

hood

1

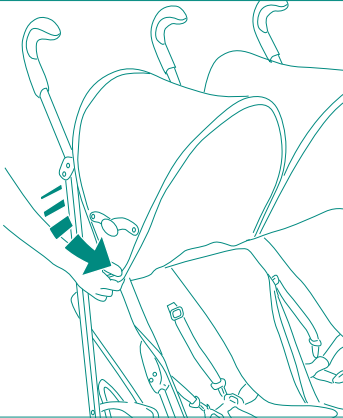

Attach the hood clips in the position shown.

2



Pull the hoods forwards and push the locks downwards

harness

1

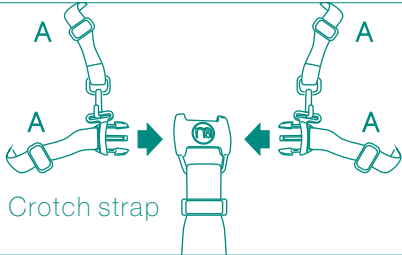

To fasten
Insert both fasteners securely into the clasp.
Adjust each strap length with buckles A.

2

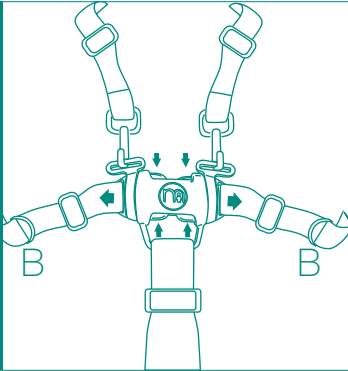

To release
Press the fastener prongs and pull apart.
'D' rings (B) are provided for fitting a separate harness complying with BS 6684 or BS EN 13210.

Your child should be securely harnessed at all times and should never be left unattended, even for short periods.

brakes

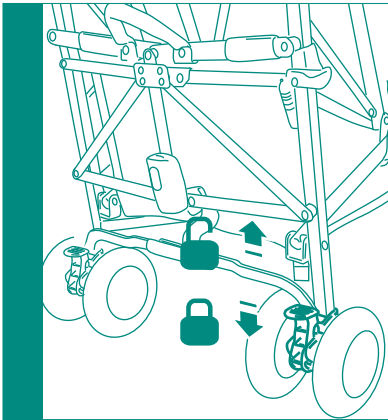

Push down on any brake pedal to start engaging the brakes.
Push down on the metal bar to engage fully.
Pull up to release the brakes.

Check that the brakes have engaged correctly by gently pushing the stroller.

backrest

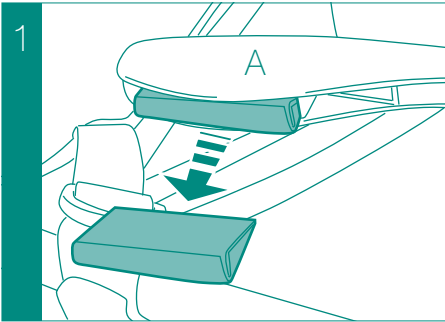

The adjusters (A) may have protective packing inside. Please ensure this is removed before using the stroller.

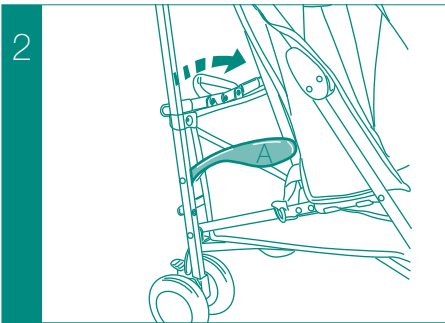

The backrest can be reclined to a choice of positions. First push the seat forwards slightly to release the seat adjusters (A).

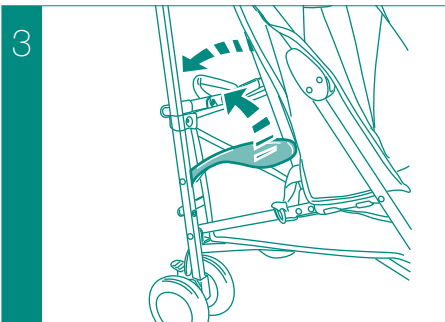

Lift the seat adjusters (A) on each side of the backrest, and at the same time, raise or lower the seat back to the desired position. Push the seat adjusters down, always ensuring that the seat is secure before use.

fitting the rain cover

1

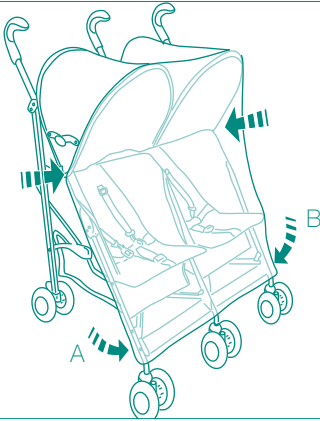

Place the rain cover over the hood.
Attach the fasteners on each side of the top of the cover as indicated.

Attach **tabs** A-B as shown.

2

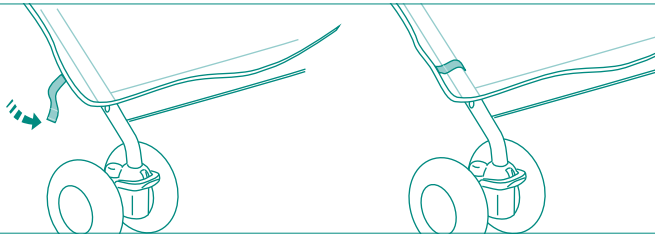

swivel locks



To lock the swivels - align the front wheels
and raise each lock.
To unlock the swivels - push down on each lock.

folding

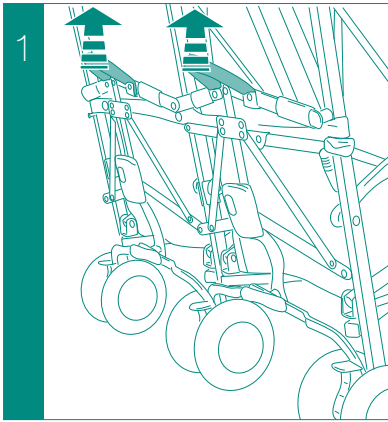

1 Empty the basket and lift the main lock up.

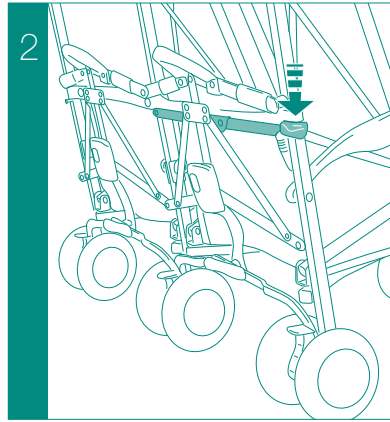

2 Press the secondary lock down.

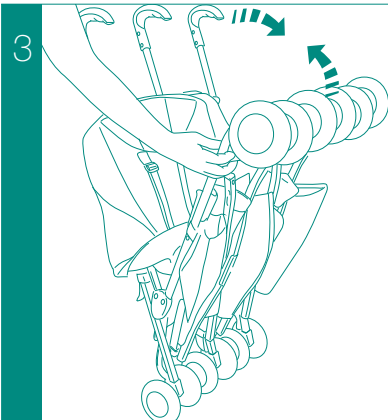

3 Push the handles forward.

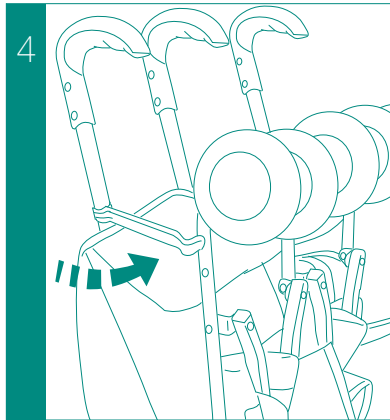

4 Secure the **folding catch**.

- Your stroller requires maintenance by you.
- Regularly inspect the locks, brakes, harness, catches, seat adjusters, joints and fixings to ensure they are secure and in full working order.
- Brakes, wheels and tyres do wear and should be replaced if necessary. This can be arranged through your local Mothercare store.
- If parts become stiff or difficult to operate, ensure dirt is not the cause, then try a light silicone lubricant, ensuring it penetrates between the components. Regular lubrication of moving parts will extend the life of your stroller and make opening and folding easier.
- Plastic and metal parts may be sponged clean with warm water and a mild detergent.
- The seat may be cleaned by sponging lightly using warm water and a mild detergent. Dry thoroughly before storing.
- Never clean with abrasive, ammonia based, bleach based or spirit type cleaners.
- After exposure to damp conditions, dry off with a soft cloth and leave fully open in a warm environment. Storing damp will encourage mildew to form. Store in a dry safe place.
- Do not leave in sunlight for prolonged periods - some fabrics may fade.
- Your stroller should be serviced and reconditioned before using it for a second baby, or within 18 months, whichever is the sooner. This can be arranged by your local Mothercare store.

- YOUR CHILD'S SAFETY IS YOUR RESPONSIBILITY.
- Designed and tested to comply with BS 7409:1996.
- Do not allow your child to climb unassisted into the stroller.
- Ensure your child wears a correctly fitted and adjusted harness at all times. For extra safety, D-rings are provided for a separate safety harness approved to BS 6684 or BS EN 13210.
- Ensure children are clear of moving parts before making adjustments.
- Overloading, incorrect folding and the use of non-approved accessories may damage or break this stroller.
- Never leave raincovers, hoods or aprons on indoors, in a hot atmosphere or near a heat source - your child may overheat.
- Do not use replacement parts or accessories, e.g. child seats, bag hooks, raincovers etc. other than those approved by Mothercare as they may make the stroller unsafe.
- Do not overload with additional children, goods or accessories. Bags and other items must not be hung from the handle.
- Always apply the brakes when stationary.
- Be careful when going up or down kerbs. Remove your child and fold the stroller when going up or down stairs or escalators.
- Do not use your stroller in a manner for which it is not designed.
- Do not let children play with or hang on to the stroller.
- Hold on to your stroller when close to moving road vehicles or trains. Even with the brake on, the draught from the vehicle may move the stroller.
- If your stroller is used by someone unfamiliar with it e.g. grandparents always show them how it works.
- Never leave your child unattended, even for the shortest time.