

your child's safety is your responsibility

If you have a problem with this product or require replacement parts, please contact your nearest Mothercare store or telephone the Mothercare customer care line on **08453 30 40 30**

Alternatively write to:

Customer Care
Mothercare
Cherry Tree Road
Watford
Herts. WD24 6SH

www.mothercare.com



newbury cot user guide



IMPORTANT - READ CAREFULLY AND KEEP FOR FUTURE REFERENCE

important notes

This cot conforms to BS EN 716 -1: 1996, Safety Standard for Cots.

Please take a few minutes to read this user guide.

Unpack your cot carefully onto a soft level surface, such as a carpeted floor.

Familiarise yourself with the parts by comparing them with the PARTS CHECK LIST below. Do not discard any packaging until you are sure you have all the parts.

The Recommended mattress for this cot is a Mothercare "Continental" sized mattress, (120cm x 60cm).

parts check list

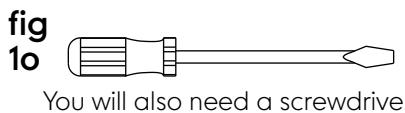
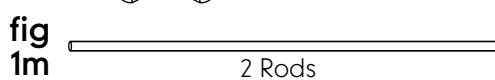
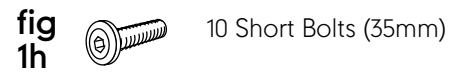
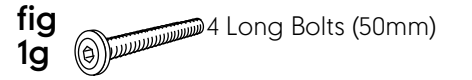
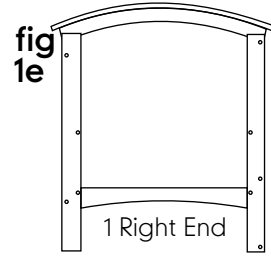
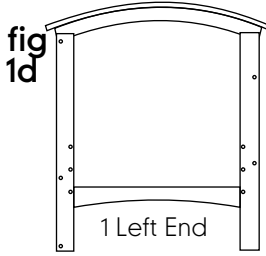
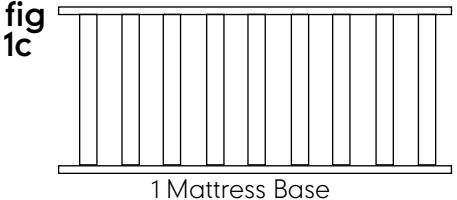
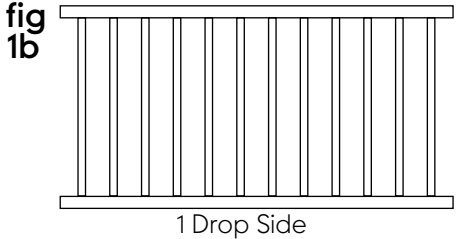
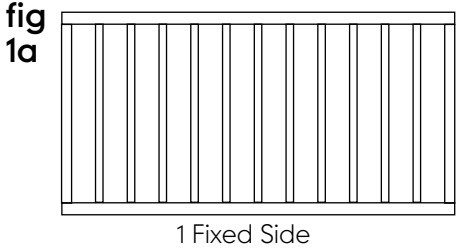

assembly

fig 2

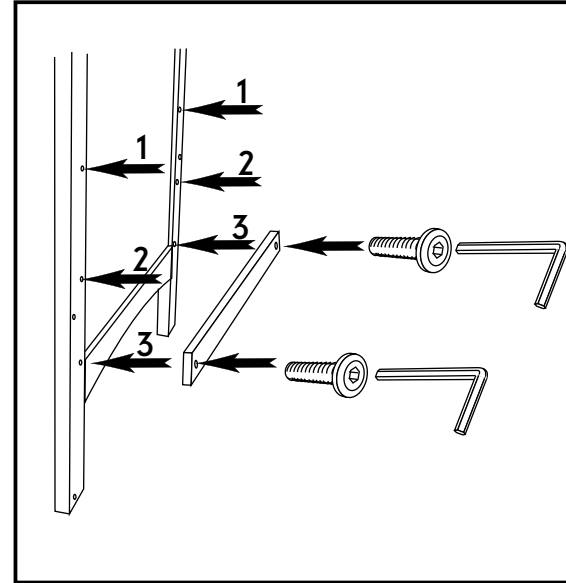

Your cot has 3 mattress base positions. Decide which mattress base position you require now. The lowest base position is the safest and should always be used as soon as the baby is old enough to sit up.

Attach the Mattress Base Supports to the inside face of the Ends using 4 Short Bolts, and the Allen Key, as shown.

fig 3

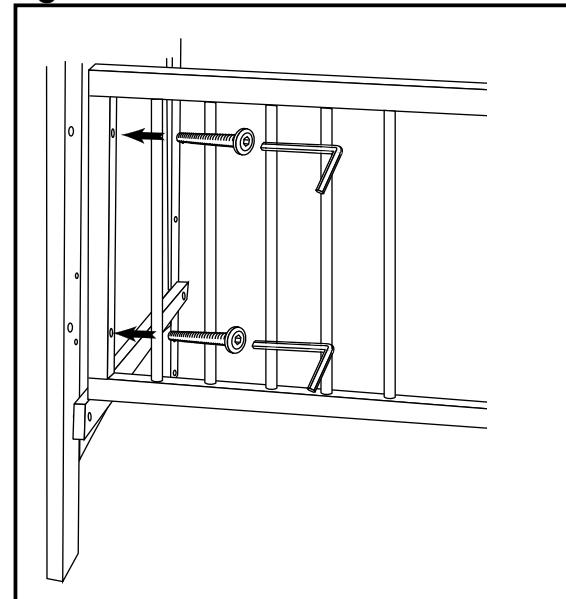

Attach the Fixed Side to both ends, using the Long Bolts and the Allen Key, as shown.

Tighten the bolts

assembly

fig 4

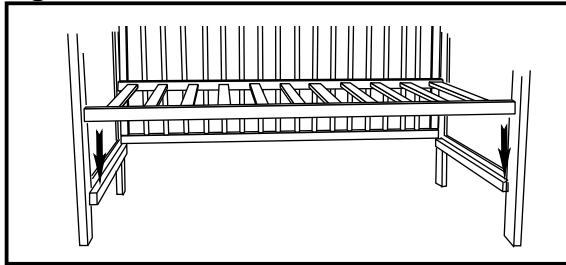

Place the Mattress Base on the Mattress Base Supports.

fig 5

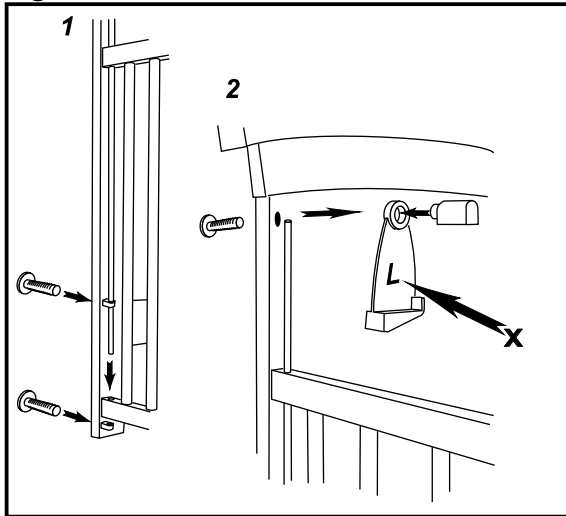

1) Attach the Lower and Middle Rod Supports, using 4 of the Short Bolts. Pass the Rods through the holes in the upper rails of the Drop Side, the Middle Supports, through the lower rail of the Drop Side and into the Lower Supports, as shown.

2) Attach the Upper Supports and Drop Side Catches as shown, using Short Bolts: the support pushes onto the rod and the catch rests between rod and leg. Note the "L" and "R" impressed on the catches (x), these stand for Left and Right respectively.

in use

fig 6

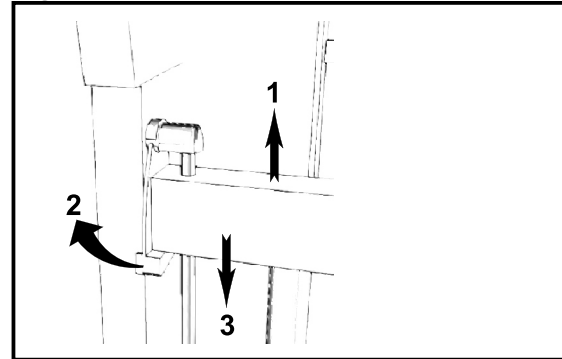

To lower the Drop Side:
1) Lift Drop Side
2) Swing both catches upwards
3) Lower the Drop Side

To raise the Drop Side:
Lift the side until both Drop Side
Catches engage.

care of your product

Periodically check all fittings to ensure that none have come loose.

The cot can be cleaned by wiping with a damp cloth and drying with a soft dry cloth.

Never clean with abrasive, ammonia based, bleach based, or spirit type cleaners.

Take care when handling or moving the cot. Careless handling can damage wooden furniture.

safety notes

The lowest base position is the safest and should always be used as soon as the baby is old enough to sit up.

Never leave anything inside the cot that could provide a foothold or present a risk of suffocation or strangulation.

If you leave the child unattended, always make sure the drop side is in the highest position.

The thickness of the mattress chosen must not reduce the internal depth (from mattress surface to the top of the side) to less than 500mm with the base in the lowest position or 200mm with the base in the highest position. The leg of the cot has a mark indicating this height.

All assembly fittings should always be tightened properly. Care should be taken that no screws are loose, because the child could trap parts of the body or clothing, (e.g. Strings, necklaces, ribbons for babies' dummies), which would pose a risk of strangulation.

The mattress used with this cot should be no more than 30mm shorter or narrower than the internal length or width of the cot.

Strong heat sources, e.g. open, electric or gas fires in the vicinity of the cot may be dangerous if placed near the cot.

