

# MACLAREN

*mx3 carrycot*

1

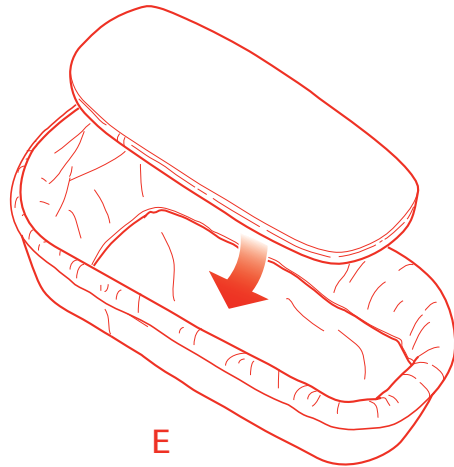

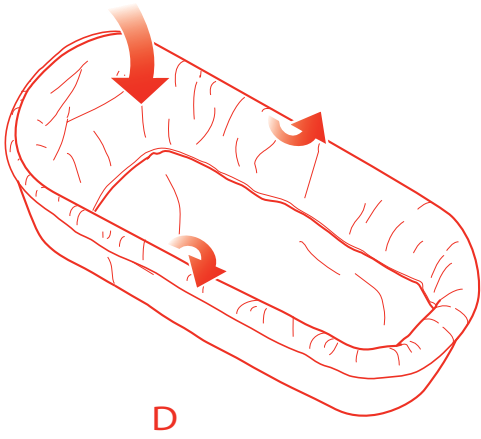
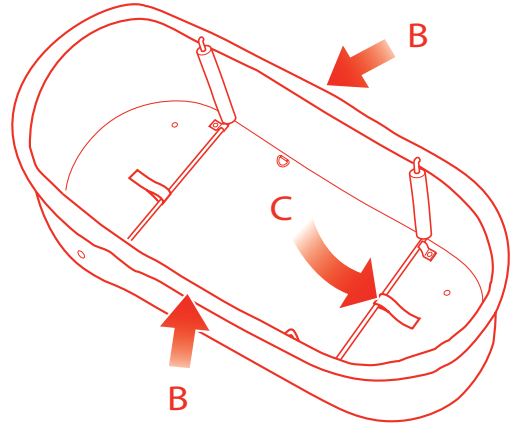
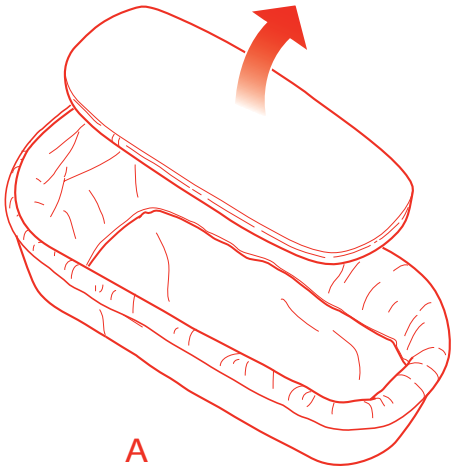
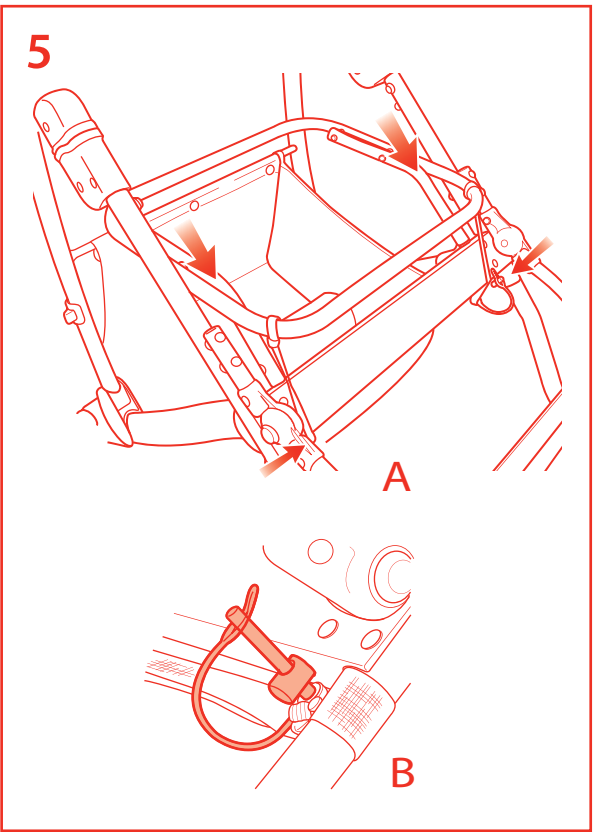
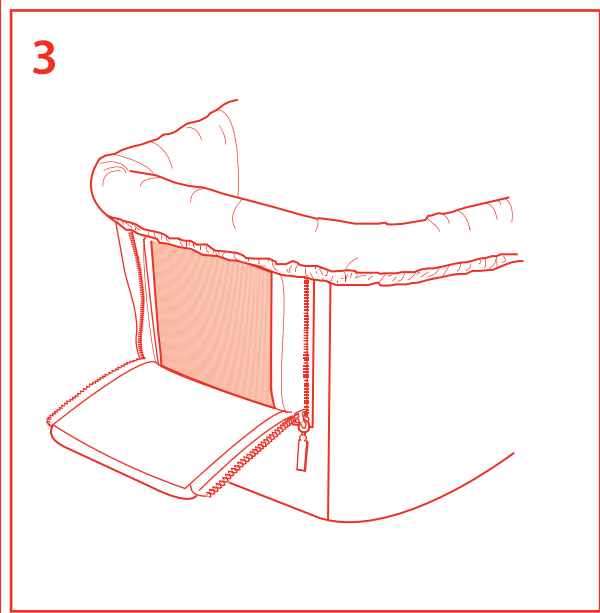
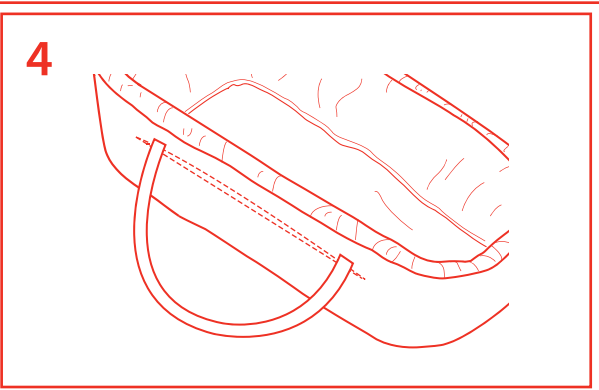
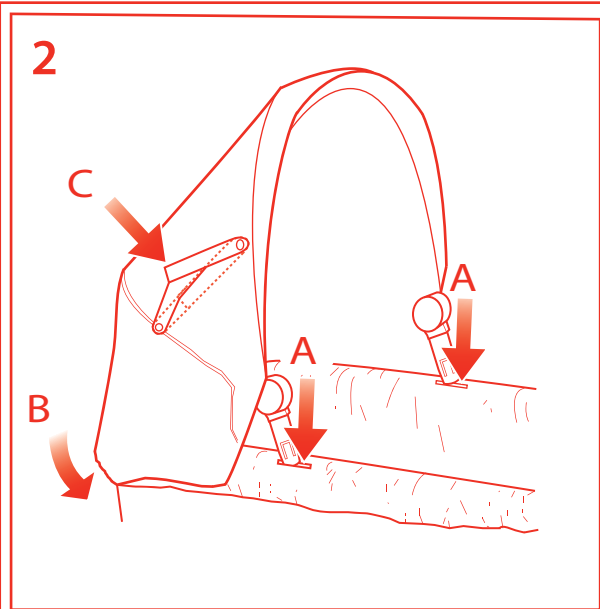

6

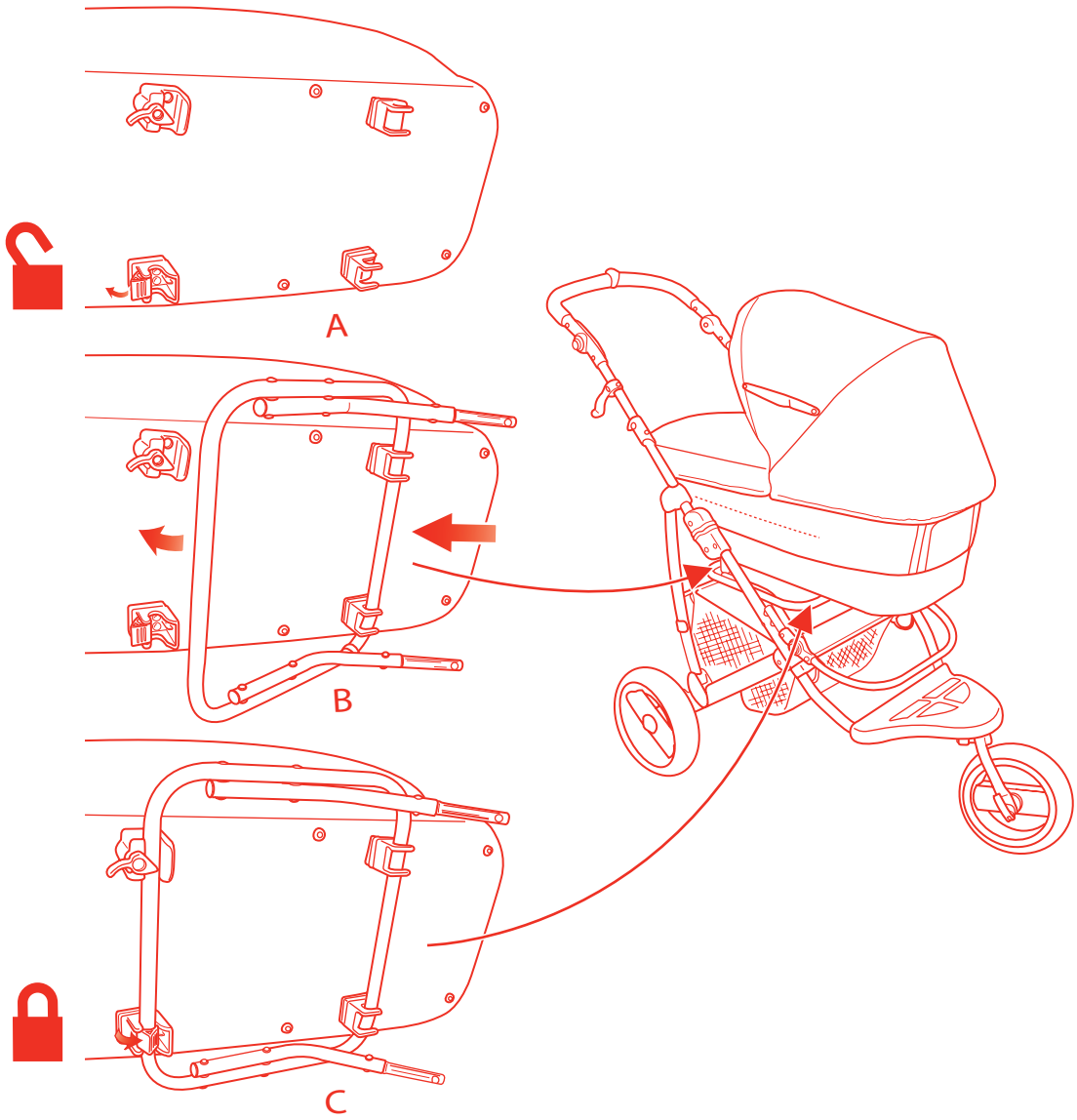

7

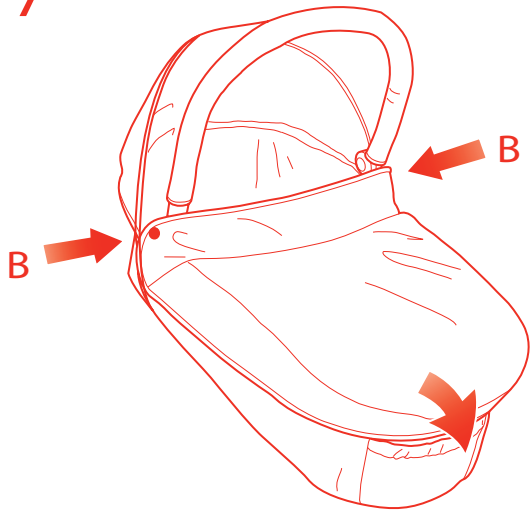

8

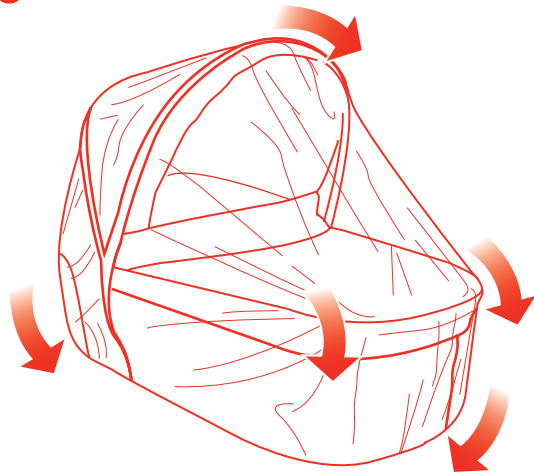

9

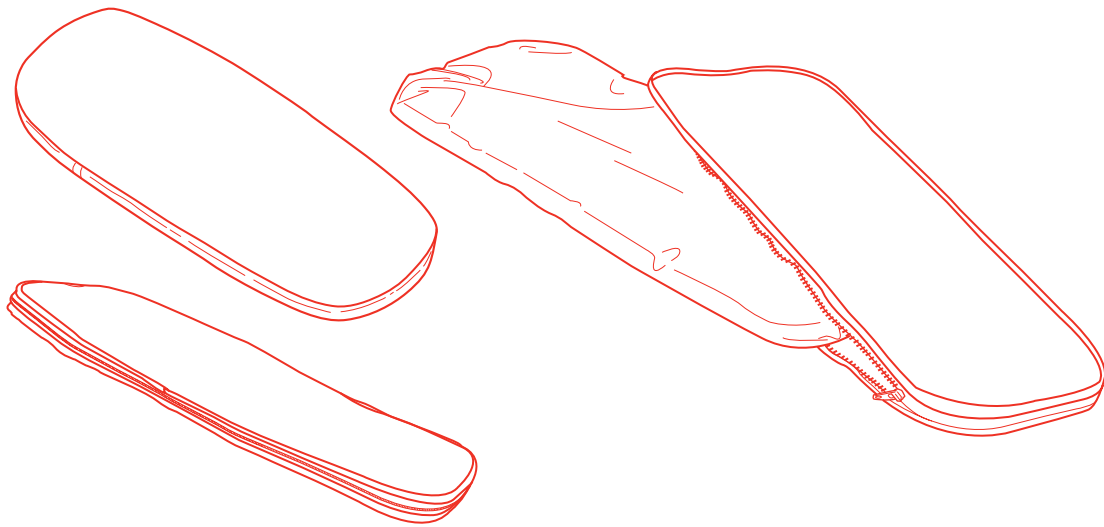

## Warranty

Your Maclaren stroller is guaranteed to be free from any manufacturing defects for a period of 1 year from the date of purchase under normal use and provided it is used in compliance with the operating instructions. This warranty extends only to the original retail purchaser and is only valid when supplied with proof of purchase. Please retain proof of purchase with this Limited Warranty.

Should a repair be needed please contact the retailer from whom the product was purchased, or one of the Maclaren Authorised Service Agents.

Please note that the warranty will not be applicable if:

A fault is the cause of misuse or poor maintenance.  
Please refer to this instruction leaflet for guidance on how to maintain your stroller.

Repairs are carried out by a third party.

The stroller is faulty due to general wear and tear which is the result of everyday use.

A stroller is damaged as a result of an accident.

Maclaren are not satisfied that the stated warranty terms and conditions have been met.

THIS WARRANTY IS GIVEN IN ADDITION TO AND DOES NOT AFFECT  
YOUR STATUTORY RIGHTS

# Contents

<b>2</b>	<b>EN</b>	<b><i>Attendant user guide</i></b> Please read this user guide fully prior to use ensuring reference is made to the numbered diagrams on the final pages. <i>This guide also includes your warranty; please keep it safe for future reference</i>
<b>5</b>		Operating Illustrations
<b>10</b>		Warranty

# EN

## General Information & Safety

**WARNING: AVOID SERIOUS INJURY FROM FALLING OR SLIDING OUT. ALWAYS USE THE SEAT HARNESS. NEVER LEAVE CHILD UNATTENDED.**

**IMPORTANT: KEEP THESE INSTRUCTIONS FOR FUTURE REFERENCE. A CHILD'S SAFETY IS YOUR RESPONSIBILITY. THIS VEHICLE IS SUITABLE FOR ONE CHILD.**

- Incorrect use will cause damage to the carrycot and may endanger your child.
- Ensure that your child wears a correctly fitted and adjusted harness, approved to EN13210 (not supplied), this should be attached to the 'D' rings provided in the base of the cot.
- The depth from the top of the mattress to the top of the side of the body at, or at any position within 300mm from the harness attachment points, should not be less than 170mm when the mattress is in position. Do not add a mattress thicker than 40mm
- (Any replacement mattress should be compliant with BS1877:Part 10 - UK only).
- **IMPORTANT - DANGER: Children should be clear of all moving parts when making adjustments. Fingertraps and scissoring actions are unavoidable during these operations.**
- This carrycot is designed for the transportation of one child. Do not carry additional children, goods or accessories except as permitted in this leaflet.
- Any damage caused by the use of accessories not supplied by Maclaren will not be covered by the terms of our warranty.
- Always remove the carrycot from the stroller or the child from the carrycot when ascending and descending stairs or escalators or when travelling on other forms of transport.
- Always place the carrycot on a firm and level surface.
- This carrycot is intended for children from birth and up to a weight of 9kg
- Refer to the leaflet supplied with your maclaren MX3 stroller for instruction regarding brakes, initial assembly and other operational details.

### CLEANING, MAINTENANCE AND REPAIR

- The correct use and maintenance of this carrycot is essential.
- Make sure that you are familiar with the operation of this carrycot and its assembly to the maclaren MX3 stroller.
- Ensure that the cot liner and mattress cover are regularly washed and aired. Follow the washing instructions on the care labels, allow them to dry naturally and thoroughly before replacing or storing. The mattress has a waterproof cover which can be sponge cleaned. Care should be taken not to puncture the cover.
- The body and hood may be lightly sponged using warm water and a mild detergent. Rinse and dry thoroughly before use.
- We recommend that you replace the mattress if you are re-using the carrycot for a subsequent child.
- For protection against the rain you must use the separate raincover provided.
- Always store in clean and dry surroundings.

Maclaren reserve the right to make design changes to any of their products as part of their continuous development programme.

**This product is designed and manufactured to comply with BS7409: 1996 (Safety requirements for wheeled child conveyances) and with EN1888:2003 (child care articles- wheeled child conveyances- safety requirements and test methods)**

# EN

## Instructions

**IMPORTANT:**

- READ THESE INSTRUCTIONS CAREFULLY BEFORE USE AND KEEP THEM FOR FUTURE REFERENCE.
- YOUR CHILDREN'S SAFETY MAY BE AFFECTED IF YOU DO NOT FOLLOW THESE INSTRUCTIONS.

### 1. TO ASSEMBLE CARRYCOT

- Remove mattress and carrycot liner.
- Raise carrycot sides.
- Swing tensioning wires down and clip to the spring retainers on carrycot base.  
**CAUTION:** Ensure tensioning wires are held securely before continuing.
- Place liner within carrycot and fold fabric over carrycot rim ensuring that the ventilation panels line up.
- Place mattress within liner.

### 2. TO ATTACH THE CARRYCOT HOOD

- Attach hood to carrycot using side clips.
- Pull the elastic over the back rim of the carrycot.
- Extend hood and push down on side hinges to lock open.  
**WARNING:** Do not lift child and cot using the hood.

### 3. TO OPEN THE VENTILATION PANEL

Unzip the ventilation panel, fold panel and secure with toggle.

### 4. USING THE CARRYCOT HANDLES

Unzip the panels on the side of the carry cot and pull out handles. Handles should be stored in the pockets when the carrycot is attached to the Maclaren MX3 stroller. DO NOT store anything other than the handles in the pockets

Your maclaren MX3 carry cot is now ready for use and can be attached to the stroller chassis. Ensure that the maclaren MX3 chassis is fully erected for use in accordance with the instructions provided with the product and all locking devices are engaged. Ensure the brakes are applied whilst attaching and detaching the carrycot.

### 5. TO ATTACH CARRYCOT ADAPTOR TO MX3 STROLLER

Remove maclaren MX3 seat (see maclaren MX3 instruction leaflet).

- Locate holes in maclaren MX3 front frame and insert adaptor legs into holes.
- Insert locking pins into adaptor legs and flip over 'D' rings to secure. For ease the locking pins can be attached to the frame using the elastic.

### 6. TO ATTACH CARRYCOT TO MX3 CARRYCOT ADAPTOR

**WARNING:** Ensure carrycot adaptor is held securely to stroller frame and parking brakes are applied before attaching the carrycot. Always fit the carrycot with the hood at the front of the stroller (hood opening facing attendant).

Only place the baby in the carrycot when all clips are secure.

- On the underside of the carrycot there are two hooks, one automatic clip and one red manual locking clip. Open the red manual locking clip.
- Firstly attach hooks to the rear bar.
- Push down on the front of carrycot to engage the automatic clip. Close red manual locking clip over bar.
- Test to ensure that both hooks and both locking clips are attached and the carrycot is securely held.  
**IMPORTANT, WARNING:** Check that the carrycot attachment devices are correctly engaged before use and that the carrycot is secure failure to do so will endanger your child's safety.
- To remove the carrycot manually unlock both locking clips and reverse the process  
**CAUTION:** Remove carrycot before folding stroller.

### 7. TO FIT APRON

- Place apron over carrycot.
- Attach press studs to hood sides.

### 8. TO FIT RAIN COVER

Place rain cover over upright hood and wrap around carrycot base.

### 9. CARRYCOT MATTRESS

- The mattress cover can be unzipped and removed to be washed.
- When placing the mattress back in cover ensure that it is the right way with the hard protective side facing the bottom of the carrycot.